

MXP BAND CYLINDER

N INTERNAL BEARING

S SOLID BEARING

P PROFILED RAIL



CONTENTS

Introduction	MXP_2
Comparison	MXP_3
N Internal Bearing Features	MXP_4
S Solid Bearing Features	MXP_6
P Profiled Rail Features	MXP_8
N Moment and Load Capacity	MXP_10
S Moment and Load Capacity	MXP_12
P Moment and Load Capacity	MXP_14
Load Deflection	MXP_16
Specifications	MXP_17
Cushion & Shock Absorber	MXP_18
Tube Clamp Requirements	MXP_19
N Internal Bearing Dimensions	MXP_21
S Solid Bearing Dimensions	MXP_26
P Profiled Rail Dimensions	MXP_31
Switches	MXP_36
Selection Guidelines	MXP_38
Adjustment Procedures	MXP_40
Service Parts	MXP_41
Ordering	MXP_44

INTRODUCING THE MXP BAND CYLINDER – DESIGNED TO OUTLAST EVERY RODLESS CYLINDER ON THE MARKET

The MXP pneumatic rodless cylinder is exactly what you expect from the industry's number one rodless supplier. Designed with our exclusive ENDURANCE TECHNOLOGYSM features, the MXP delivers superior performance to meet the most demanding applications. Nobody knows rodless like Tolomatic, and the MXP proves it.

- **DURABLE BEARINGS.** Three bearing choices to match your application needs. Profiled rail design reduces friction and extends actuator life. Solid bearing design reduces stress concentration for optimum performance. Internal bearing design is permanently lubricated for long, trouble-free service.
- **DURABLE BANDS.** Stainless steel bands are stronger and will not elongate like elastomer (non-metallic) bands, providing reliable sealing over the life of the actuator.



[N]-INTERNAL BEARING

- Low cost solution for applications with limited load and bending moment requirements
- Lowest breakaway pressure
- Best in many vertical applications
- Permanently lubed internal bearing

[S]-SOLID BEARING

- Increased Mx moment capacity
- Large bearing surface contact area optimizes stress distribution on bearing for long service life
- Large carrier mounting pattern for more load stability and compatibility with existing BC2 applications
- Engineered bearing material does not require additional lubrication
- Solid bearings are field replaceable

[P]-PROFILED RAIL

- Recirculating ball bearing design offers reduced friction for reliable service life
- High load and bending moment capacities
- Low profile to fit your application
- High precision bearings feature smooth, low breakaway motion

SELECT THE PERFORMANCE YOU NEED

Choose from: • Three Bearing Models • Six Bore Sizes • Built to Your Specified Stroke Length!

MOMENT & LOAD CAPACITY COMPARISON

Graph for model comparison, data from MXP40, 38mm (1.5") bore

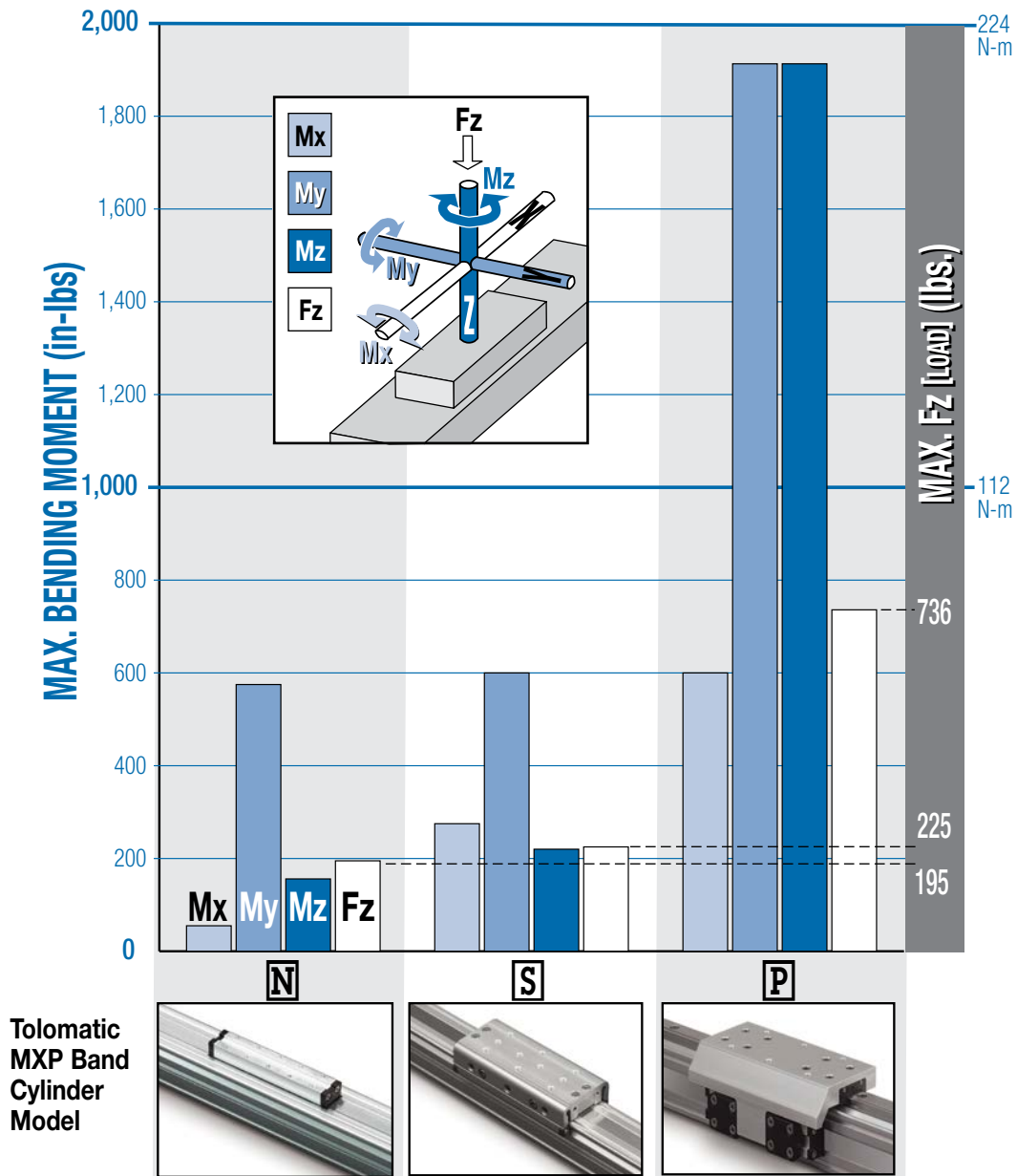

Tolomatic MXP Band Cylinder Model	N	S	P
Bearing Type	Internal Bearing	Solid Bearing	Profiled Rail
Moment Capacity	Moderate	Moderate + Mx	High
Isolated Piston	No	Yes	Yes
Ideal Applications	<ul style="list-style-type: none"> Guided Loads Vertical Orientation 	<ul style="list-style-type: none"> Side Loads Impact Loads 	<ul style="list-style-type: none"> High Moment Loads High Speeds with Heavy Loads High Precision
Product Details	Page MXP_4	Page MXP_6	Page MXP_8

N INTERNAL BEARING

STAINLESS STEEL BANDS

- Both interior sealing band and exterior dust band made of fatigue resistant stainless steel
- Does not stretch like bands made of rubber or polymer materials
- Stainless steel sealing bands resist blow out during pressure spikes that may occur during high velocity cushioning



STAINLESS STEEL IS DURABLE, FLEXIBLE AND CORROSION RESISTANT

RETAINED DUST BAND

Retained dust band keeps contaminants from entering the cylinder interior, protecting components for reduced maintenance and increased uptime

INTERNAL BEARINGS



- Design maximizes piston bearing surface area for less pressure on bearing surfaces, less pressure results in less wear
- Permanent lubrication for low friction and extended bearing life
- Internal location provides protection from external contaminants, extending life

NON-WEAR BAND RETENTION

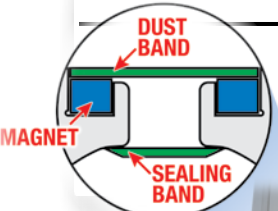

- Magnetically retained bands are not subject to wear as are mechanically retained systems
- Immediate band engagement and release results in less drag on piston for lower breakaway force during initial carrier movement

ADJUSTABLE CUSHIONS

- Easy screw adjustment for smooth deceleration protecting actuator from high stress at end-of-stroke
- Adjustable cushions with retained stainless steel needle screw for increased safety

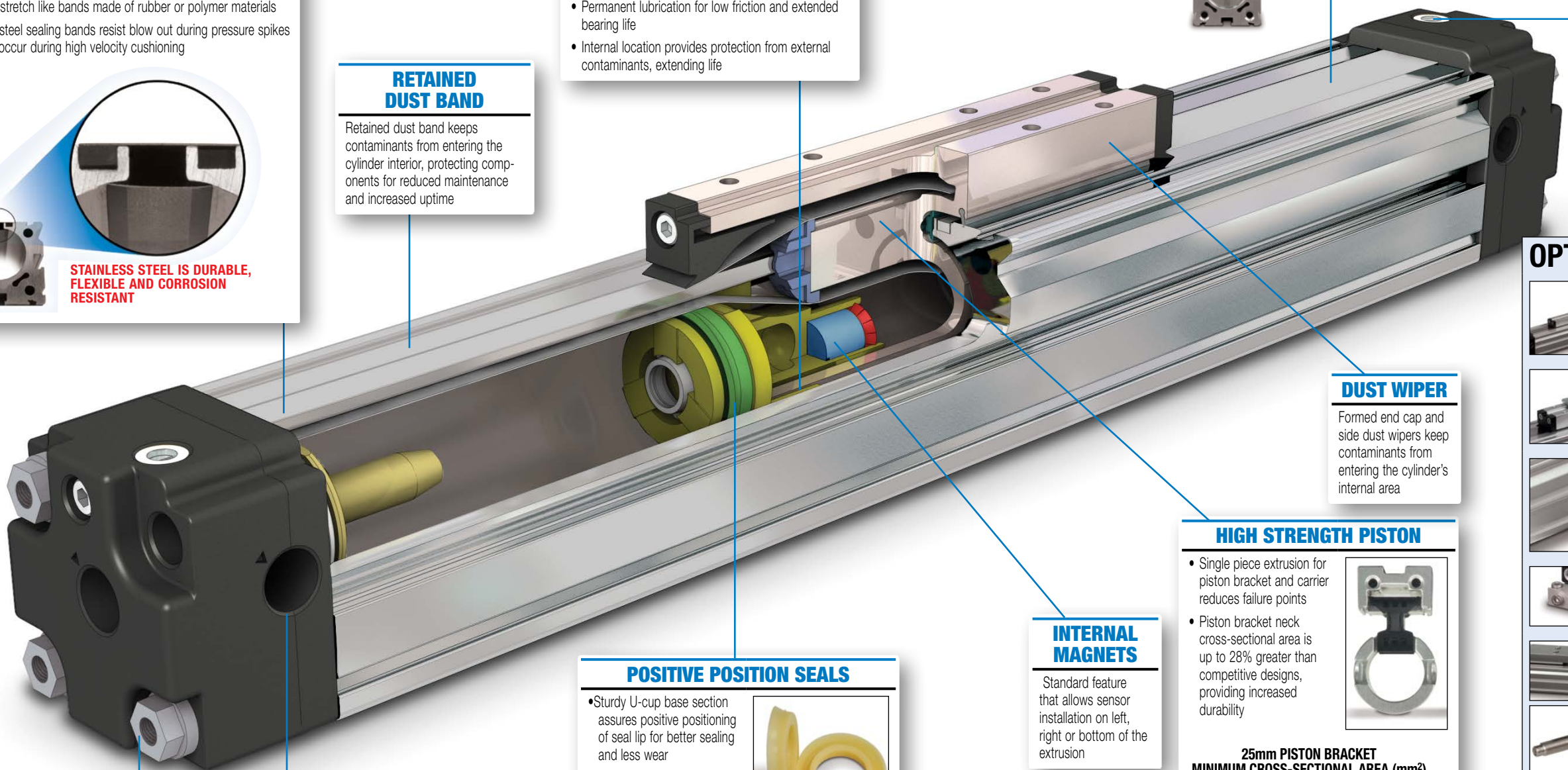

NOTE: Boxed letters indicate ordering codes

OPTIONS

- AUXILIARY CARRIER DW**
 - 2X higher Fz (load) capacity
 - High bending moment capacity
- FLOATING MOUNT FL**
 - Compensates for non-parallelism between MXP band cylinder and externally guided load
- TUBE CLAMPS TC**
 - Used for intermediate support
 - Flush with bottom of actuator to retain low profile
 - Drop-in, adjustable mounting locations
- FOOT MOUNTS FM**
 - For end mounting of MXP band cylinder
 - Use to bottom or side mount actuator
- SHOCK ABSORBERS ALSL
AHSH**
 - Allows increased operating speed and load
 - Self-compensates for load or speed changes
 - Minimizes impact load to equipment
 - Fixed or adjustable position shocks
- SINGLE-END PORTING S**
 - Convenient single-end air connection (not available on MXP16)
- SWITCHES**
 - Wide variety of sensing choices: Reed, Solid State PNP or NPN, all available normally open or normally closed
 - Flush mount, drop-in installation, anytime
 - Bright LEDs, power & signal indication
 - CE rated, RoHS compliant

DUST WIPER

Formed end cap and side dust wipers keep contaminants from entering the cylinder's internal area

HIGH STRENGTH PISTON

- Single piece extrusion for piston bracket and carrier reduces failure points
- Piston bracket neck cross-sectional area is up to 28% greater than competitive designs, providing increased durability

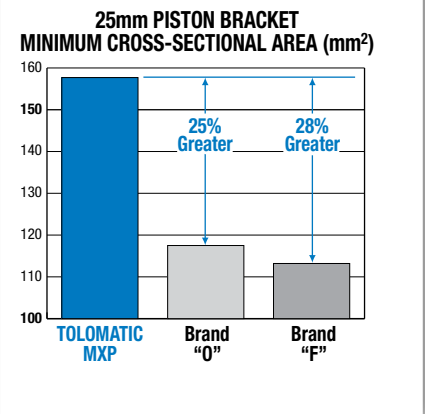



INTERNAL MAGNETS

Standard feature that allows sensor installation on left, right or bottom of the extrusion

POSITIVE POSITION SEALS

- Sturdy U-cup base section assures positive positioning of seal lip for better sealing and less wear
- Made of custom formulated polyurethane for pliable, wear resistant seal lip



DIRECT MOUNT

Head bolts are tapped for direct mounting

INCH OR METRIC MOUNTING

Your choice of inch (US standard) or metric fasteners for carrier and head bolt mounting

PORTING CHOICES

- 4-ported heads are standard to allow air connections on sides, end or bottom
- Single-end porting allows convenient one end air connection
- NPT, Metric Parallel (ISO-G/BSP) & Metric Taper (Rc/BST) available on both metric and inch (US standard) mount actuators

STAINLESS STEEL BANDS

- Both interior sealing band and exterior dust band made of fatigue resistant stainless steel
- Does not stretch like bands made of rubber or polymer materials
- Stainless steel sealing bands resist blow out during pressure spikes that may occur during high velocity cushioning



STAINLESS STEEL IS DURABLE, FLEXIBLE AND CORROSION RESISTANT

POSITIVE POSITION SEALS

- Sturdy U-cup base section assures positive positioning of seal lip for better sealing and less wear
- Made of custom formulated polyurethane for pliable, wear resistant seal lip



INTERNAL MAGNETS

Standard feature that allows sensor installation on left, right or bottom of the extrusion

DUST WIPER

Formed end cap and side dust wipers keep contaminants from entering the cylinder's internal area

ADJUSTABLE CUSHIONS

- Easy screw adjustment for smooth deceleration protecting actuator from high stress at end-of-stroke
- Adjustable cushions with retained stainless steel needle screw for increased safety

NON-WEAR BAND RETENTION

- Magnetically retained bands are not subject to wear as are mechanically retained systems
- Immediate band engagement and release results in less drag on piston for lower breakaway force during initial carrier movement

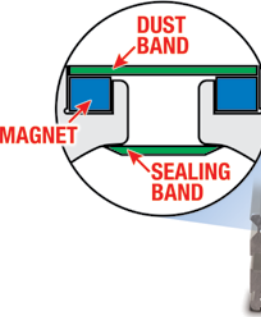

RETAINED DUST BAND

Retained dust band keeps contaminants from entering the cylinder interior, protecting components for reduced maintenance and increased uptime

LARGE FLEXIBLE MOUNTING PATTERN

- Carrier gives more load stability
- Compatibility with existing BC2 applications
- More fastening options

NON-BINDING BEARING ARMS

Bearings are tensioned indirectly, providing bind free adjustment

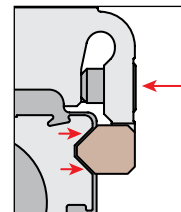

ISOLATED PISTON

- Unique design isolates the piston from the applied load, extending the service life of the piston seals
- Piston remains isolated even when the carrier is deflected under load
- Piston bracket and carrier feature single piece extrusions, reducing failure points

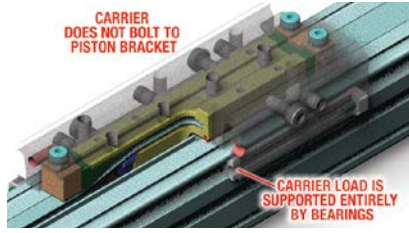

CARRIER DOES NOT BOLT TO PISTON BRACKET

CARRIER LOAD IS SUPPORTED ENTIRELY BY BEARINGS

TRAPEZOIDAL BEARINGS

- Trapezoidal design maximizes bearing surface area for less pressure on bearing surfaces; less pressure results in less wear
- Engineered bearing material has low static and dynamic friction with low wear properties for long lasting, smooth operation
- Bearings are field replaceable for extended service life

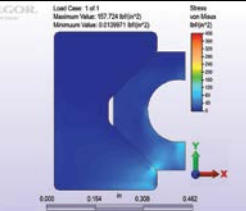
OPTIONS

- AUXILIARY CARRIER **DW****
 - 2X higher Fz (load) capacity
 - High bending moment capacity
- FLOATING MOUNT **FL****
 - Compensates for non-parallelism between MXP band cylinder and externally guided load
- TUBE CLAMPS **TC****
 - Used for intermediate support
 - Flush with bottom of actuator to retain low profile
 - Drop-in, adjustable mounting locations
- FOOT MOUNTS **FM****
 - For end mounting of MXP band cylinder
 - Use to bottom or side mount actuator
- SHOCK ABSORBERS **ALS** **ASH****
 - Allows increased operating speed and load
 - Self-compensates for load or speed changes
 - Minimizes impact load to equipment
 - Fixed or adjustable position shocks
- SINGLE-END PORTING **S****
 - Convenient single-end air connection (not available on MXP16)
- SWITCHES**
 - Wide variety of sensing choices: Reed, Solid State PNP or NPN, all available normally open or normally closed
 - Flush mount, drop-in installation, anytime
 - Bright LEDs, power & signal indication
 - CE rated, RoHS compliant

NOTE: Boxed letters indicate ordering codes

DIRECT MOUNT

Head bolts are tapped for direct mounting

INCH OR METRIC MOUNTING

Your choice of inch (US standard) or metric fasteners for carrier and head bolt mounting

PORTING CHOICES

- 4-ported heads are standard to allow air connections on sides, end or bottom
- Single-end porting allows convenient one end air connection
- NPT, Metric Parallel (ISO-G/BSP) & Metric Taper (Rc/BST) available on both metric and inch (US standard) mount actuators

P PROFILED RAIL

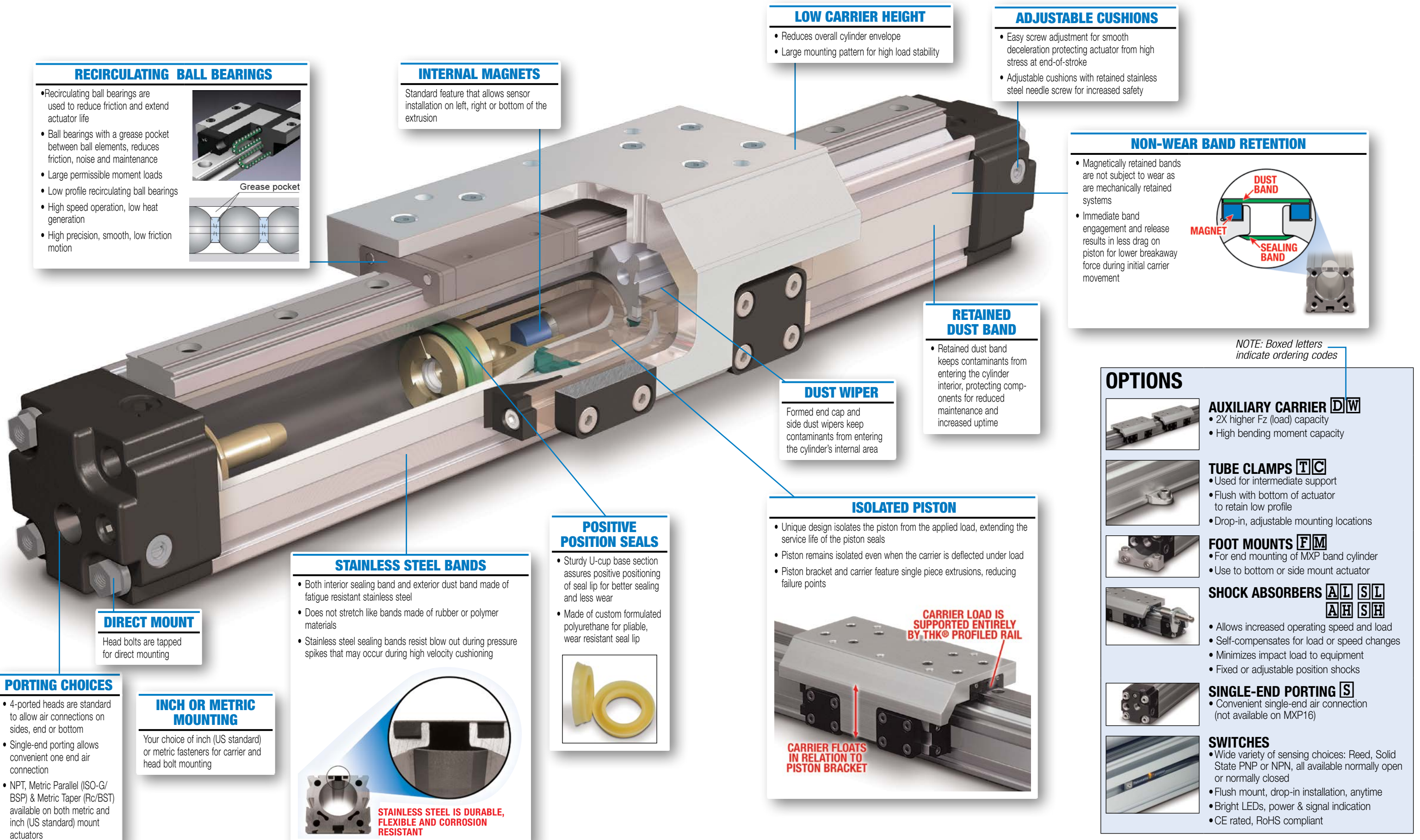

RECIRCULATING BALL BEARINGS

- Recirculating ball bearings are used to reduce friction and extend actuator life
- Ball bearings with a grease pocket between ball elements, reduces friction, noise and maintenance
- Large permissible moment loads
- Low profile recirculating ball bearings
- High speed operation, low heat generation
- High precision, smooth, low friction motion

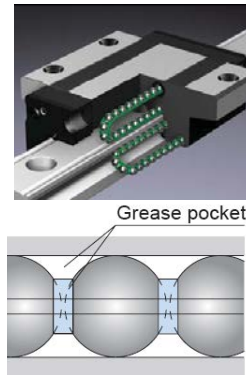

INTERNAL MAGNETS

Standard feature that allows sensor installation on left, right or bottom of the extrusion

LOW CARRIER HEIGHT

- Reduces overall cylinder envelope
- Large mounting pattern for high load stability

ADJUSTABLE CUSHIONS

- Easy screw adjustment for smooth deceleration protecting actuator from high stress at end-of-stroke
- Adjustable cushions with retained stainless steel needle screw for increased safety

NON-WEAR BAND RETENTION

- Magnetically retained bands are not subject to wear as are mechanically retained systems
- Immediate band engagement and release results in less drag on piston for lower breakaway force during initial carrier movement

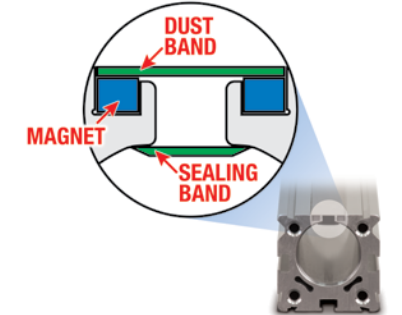

NOTE: Boxed letters indicate ordering codes

RETAINED DUST BAND

- Retained dust band keeps contaminants from entering the cylinder interior, protecting components for reduced maintenance and increased uptime

DUST WIPER

Formed end cap and side dust wipers keep contaminants from entering the cylinder's internal area

ISOLATED PISTON

- Unique design isolates the piston from the applied load, extending the service life of the piston seals
- Piston remains isolated even when the carrier is deflected under load
- Piston bracket and carrier feature single piece extrusions, reducing failure points

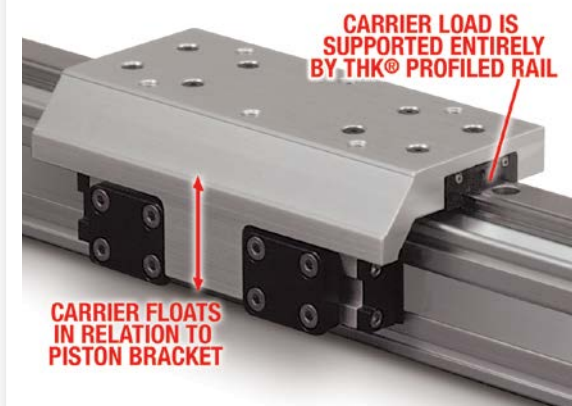

POSITIVE POSITION SEALS

- Sturdy U-cup base section assures positive positioning of seal lip for better sealing and less wear
- Made of custom formulated polyurethane for pliable, wear resistant seal lip



STAINLESS STEEL BANDS

- Both interior sealing band and exterior dust band made of fatigue resistant stainless steel
- Does not stretch like bands made of rubber or polymer materials
- Stainless steel sealing bands resist blow out during pressure spikes that may occur during high velocity cushioning



DIRECT MOUNT

Head bolts are tapped for direct mounting

PORTING CHOICES

- 4-ported heads are standard to allow air connections on sides, end or bottom
- Single-end porting allows convenient one end air connection
- NPT, Metric Parallel (ISO-G/BSP) & Metric Taper (Rc/BST) available on both metric and inch (US standard) mount actuators

INCH OR METRIC MOUNTING

Your choice of inch (US standard) or metric fasteners for carrier and head bolt mounting

OPTIONS



- ### AUXILIARY CARRIER **DW**
- 2X higher Fz (load) capacity
 - High bending moment capacity



- ### TUBE CLAMPS **TC**
- Used for intermediate support
 - Flush with bottom of actuator to retain low profile
 - Drop-in, adjustable mounting locations



- ### FOOT MOUNTS **FM**
- For end mounting of MXP band cylinder
 - Use to bottom or side mount actuator



- ### SHOCK ABSORBERS **AL SL AH SH**
- Allows increased operating speed and load
 - Self-compensates for load or speed changes
 - Minimizes impact load to equipment
 - Fixed or adjustable position shocks



- ### SINGLE-END PORTING **S**
- Convenient single-end air connection (not available on MXP16)



- ### SWITCHES
- Wide variety of sensing choices: Reed, Solid State PNP or NPN, all available normally open or normally closed
 - Flush mount, drop-in installation, anytime
 - Bright LEDs, power & signal indication
 - CE rated, RoHS compliant

STANDARD

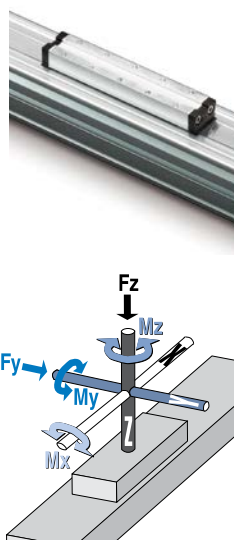

BORE			MAXIMUM BENDING MOMENTS			MAX. LOAD	THRUST
			Mx	My	Mz	Fz	(at 100 PSI)
1 6	Inch	0.63 in	3 in-lbs	35 in-lbs	5 in-lbs	30 lbf	30.7 lbf
	Metric	16 mm	0.3 N-m	4.0 N-m	0.6 N-m	133 N	136 N
2 5	Inch	1.00 in	9 in-lbs	132 in-lbs	27 in-lbs	65 lbf	78.5 lbf
	Metric	25 mm	1.0 N-m	14.9 N-m	3.1 N-m	289 N	349 N
3 2	Inch	1.25 in	36 in-lbs	318 in-lbs	120 in-lbs	115 lbf	123 lbf
	Metric	32 mm	4.1 N-m	35.9 N-m	13.6 N-m	512 N	546 N
4 0	Inch	1.50 in	55 in-lbs	575 in-lbs	156 in-lbs	195 lbf	177 lbf
	Metric	38 mm	6.2 N-m	65 N-m	17.6 N-m	867 N	786 N
5 0	Inch	2.00 in	98 in-lbs	1,017 in-lbs	172 in-lbs	270 lbf	314 lbf
	Metric	50 mm	11.1 N-m	115 N-m	19.4 N-m	1,201 N	1,397 N
6 3	Inch	2.50 in	120 in-lbs	1,776 in-lbs	216 in-lbs	370 lbf	491 lbf
	Metric	64 mm	13.6 N-m	201 N-m	24.4 N-m	1,646 N	2,184 N

The moment and load capacity of the actuator's bearing system is based on an L10 life of 200,000,000 linear inches of travel. Life of the actuator will vary for each application depending on the combined loads, motion parameters and operating conditions. The load factor (L_F) ratios for each application must not exceed a value of 1 (as calculated below). Exceeding a load factor of 1 will diminish the actuator's rated life.

$$L_F = \frac{M_x}{M_{x_{max}}} + \frac{M_y}{M_{y_{max}}} + \frac{M_z}{M_{z_{max}}} + \frac{F_y}{F_{y_{max}}} + \frac{F_z}{F_{z_{max}}} \leq 1$$

With combined loads, L_F must not exceed the value 1.

 Ratings are the maximum values for shock-free, vibration-free operation in a typical industrial environment. Contact Tolomatic for assistance in selecting the most appropriate actuator for your application.



tolomatic.com/ask
 Technical support
 before and after
 purchase

DW AUXILIARY CARRIER

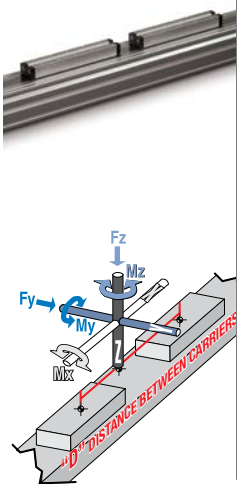

BORE			"D" MIN	MAXIMUM BENDING MOMENTS			MAX. LOAD	THRUST
				MxA	MyA*	MzA*	FzA	(at 100 PSI)
1 6	Inch	0.63 in	5.0 in	3 in-lbs	150 in-lbs	81 in-lbs	60 lbf	30.7 lbf
	Metric	16 mm	127 mm	0.3 N-m	16.9 N-m	9.1 N-m	267 N	136 N
2 5	Inch	1.00 in	6.0 in	9 in-lbs	390 in-lbs	143 in-lbs	130 lbf	78.5 lbf
	Metric	25 mm	152 mm	1.0 N-m	44.1 N-m	16.2 N-m	578 N	349 N
3 2	Inch	1.25 in	7.0 in	36 in-lbs	805 in-lbs	302 in-lbs	230 lbf	123 lbf
	Metric	32 mm	178 mm	4.1 N-m	91.0 N-m	34.1 N-m	1,023 N	546 N
4 0	Inch	1.50 in	8.5 in	55 in-lbs	1,658 in-lbs	413 in-lbs	390 lbf	177 lbf
	Metric	38 mm	216 mm	6.2 N-m	187 N-m	46.7 N-m	1,735 N	786 N
5 0	Inch	2.00 in	8.6 in	98 in-lbs	2,322 in-lbs	707 in-lbs	540 lbf	314 lbf
	Metric	50 mm	218 mm	11.1 N-m	262 N-m	79.8 N-m	2,402 N	1,397 N
6 3	Inch	2.50 in	13.0 in	120 in-lbs	4,810 in-lbs	808 in-lbs	740 lbf	491 lbf
	Metric	64 mm	330 mm	13.6 N-m	544 N-m	91.0 N-m	3,292 N	2,184 N

*At minimum "D" distance between carriers see graph below for other distances

With combined loads, L_F must not exceed the value 1.

$$L_F = \frac{M_x}{M_{x_{max}}} + \frac{M_y}{M_{y_{max}}} + \frac{M_z}{M_{z_{max}}} + \frac{F_y}{F_{y_{max}}} + \frac{F_z}{F_{z_{max}}} \leq 1$$



Ratings are the maximum values for shock-free, vibration-free operation in a typical industrial environment. Contact Tolomatic for assistance in selecting the most appropriate actuator for your application.

Mya & Mza vs. DISTANCE

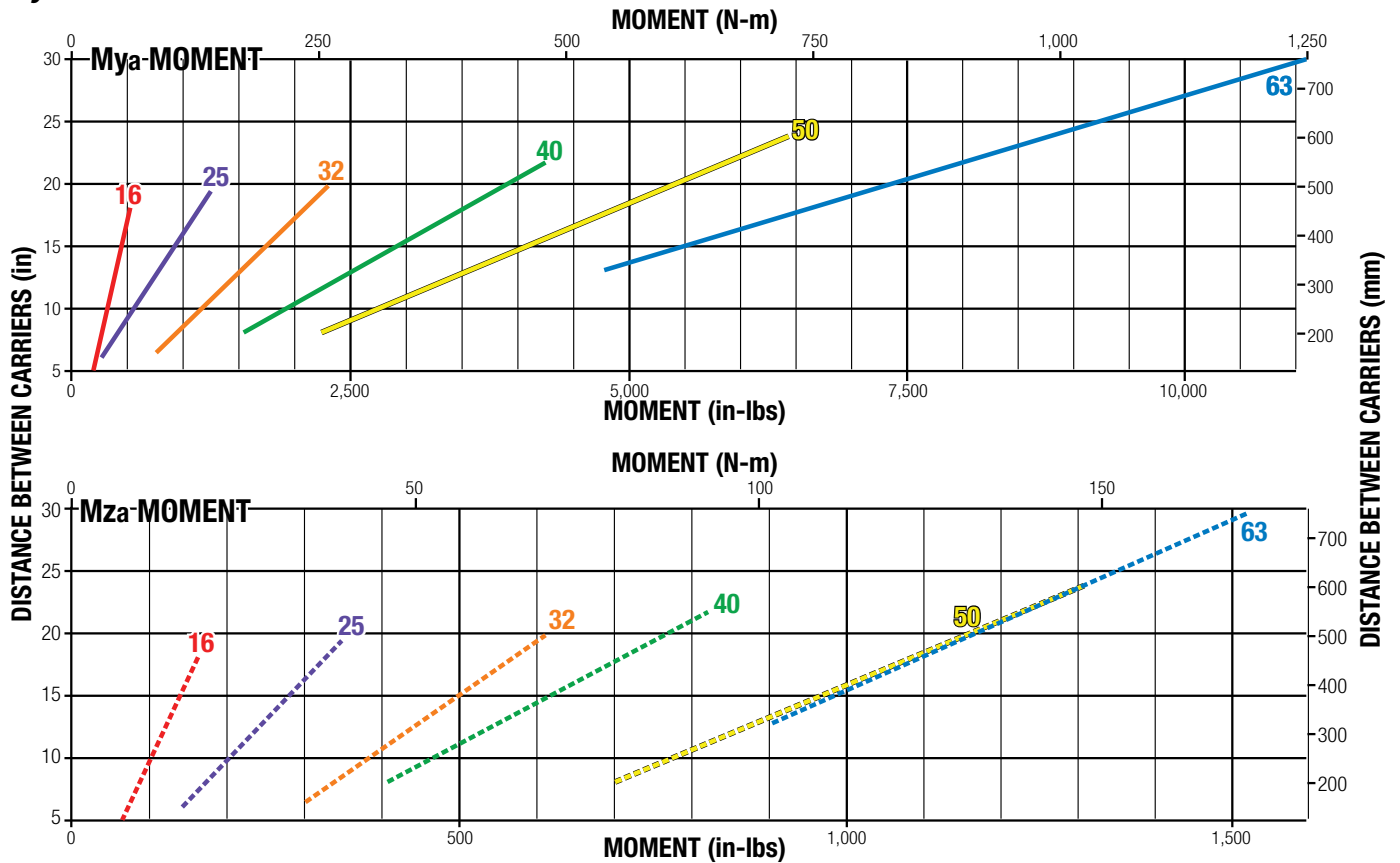

Ratings were calculated with the following conditions:

- 1.) Coupling between carriers is rigid.
- 2.) Load is equally distributed between carriers.

3.) Coupling device applies no misaligned loads to carriers.

STANDARD

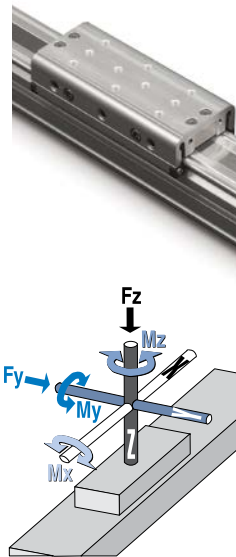

BORE			MAXIMUM BENDING MOMENTS			MAX. LOAD	THRUST
			Mx	My	Mz	Fz	(at 100 PSI)
16	Inch	0.63 in	22 in-lbs	19 in-lbs	25 in-lbs	35 lbf	30.7 lbf
	Metric	16 mm	2.5 N-m	2.1 N-m	2.8 N-m	156 N	136 N
25	Inch	1.00 in	60 in-lbs	110 in-lbs	34 in-lbs	70 lbf	78.5 lbf
	Metric	25 mm	6.8 N-m	12.4 N-m	3.8 N-m	311 N	349 N
32	Inch	1.25 in	100 in-lbs	350 in-lbs	140 in-lbs	150 lbf	123 lbf
	Metric	32 mm	11.3 N-m	39.5 N-m	15.8 N-m	667 N	546 N
40	Inch	1.50 in	275 in-lbs	600 in-lbs	220 in-lbs	225 lbf	177 lbf
	Metric	38 mm	31.1 N-m	67.8 N-m	24.9 N-m	1,001 N	786 N
50	Inch	2.00 in	315 in-lbs	1,155 in-lbs	341 in-lbs	315 lbf	314 lbf
	Metric	50 mm	35.6 N-m	131 N-m	38.5 N-m	1,401 N	1,397 N
63	Inch	2.50 in	585 in-lbs	2,340 in-lbs	520 in-lbs	520 lbf	491 lbf
	Metric	64 mm	66.1 N-m	264 N-m	58.8 N-m	2,313 N	2,184 N

The moment and load capacity of the actuator's bearing system is based on an L10 life of 200,000,000 linear inches of travel. Life of the actuator will vary for each application depending on the combined loads, motion parameters and operating conditions. The load factor (L_F) ratios for each application must not exceed a value of 1 (as calculated below). Exceeding a load factor of 1 will diminish the actuator's rated life.

$$L_F = \frac{M_x}{M_{x_{max}}} + \frac{M_y}{M_{y_{max}}} + \frac{M_z}{M_{z_{max}}} + \frac{F_y}{F_{y_{max}}} + \frac{F_z}{F_{z_{max}}} \leq 1$$

With combined loads, L_F must not exceed the value 1.



Ratings are the maximum values for shock-free, vibration-free operation in a typical industrial environment. Contact Tolomatic for assistance in selecting the most appropriate actuator for your application.



tolomatic.com/ask
 Technical support
 before and after
 purchase

DW AUXILIARY CARRIER

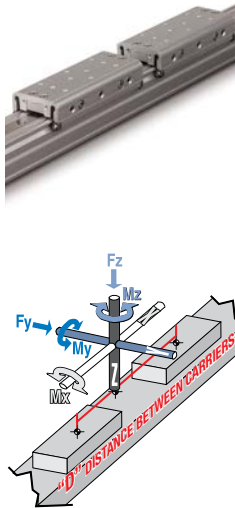

BORE			"D" MIN	MAXIMUM BENDING MOMENTS*			MAX. LOAD \$F_z\$A	THRUST (at 100 PSI)
				\$M_x\$A	\$M_y\$A	\$M_z\$A		
1 6	Inch	0.63 in	5.0 in	44 in-lbs	175 in-lbs	175 in-lbs	70 lbf	30.7 lbf
	Metric	16 mm	127 mm	5.0 N-m	19.8 N-m	19.8 N-m	311 N	136 N
2 5	Inch	1.00 in	6.0 in	120 in-lbs	420 in-lbs	420 in-lbs	140 lbf	78.5 lbf
	Metric	25 mm	152 mm	13.6 N-m	47.5 N-m	47.5 N-m	623 N	349 N
3 2	Inch	1.25 in	7.0 in	200 in-lbs	1,050 in-lbs	1,050 in-lbs	300 lbf	123 lbf
	Metric	32 mm	178 mm	22.6 N-m	119 N-m	119 N-m	1,334 N	546 N
4 0	Inch	1.50 in	8.5 in	550 in-lbs	1,913 in-lbs	1,913 in-lbs	450 lbf	177 lbf
	Metric	38 mm	216 mm	62.1 N-m	216 N-m	216 N-m	2,002 N	786 N
5 0	Inch	2.00 in	8.6 in	630 in-lbs	2,709 in-lbs	2,709 in-lbs	630 lbf	314 lbf
	Metric	50 mm	218 mm	71.2 N-m	306 N-m	306 N-m	2,802 N	1,397 N
6 3	Inch	2.50 in	13.0 in	1,170 in-lbs	6,760 in-lbs	6,760 in-lbs	1,040 lbf	491 lbf
	Metric	64 mm	330 mm	132 N-m	764 N-m	764 N-m	4,626 N	2,184 N

*At minimum "D" distance between carriers see graph below for other distances

With combined loads, \$L_f\$ must not exceed the value 1.

$$L_f = \frac{M_x}{M_{x_{max}}} + \frac{M_y}{M_{y_{max}}} + \frac{M_z}{M_{z_{max}}} + \frac{F_y}{F_{y_{max}}} + \frac{F_z}{F_{z_{max}}} \leq 1$$



Ratings are the maximum values for shock-free, vibration-free operation in a typical industrial environment. Contact Tolomatic for assistance in selecting the most appropriate actuator for your application.

\$M_y\$ & \$M_z\$ vs. DISTANCE

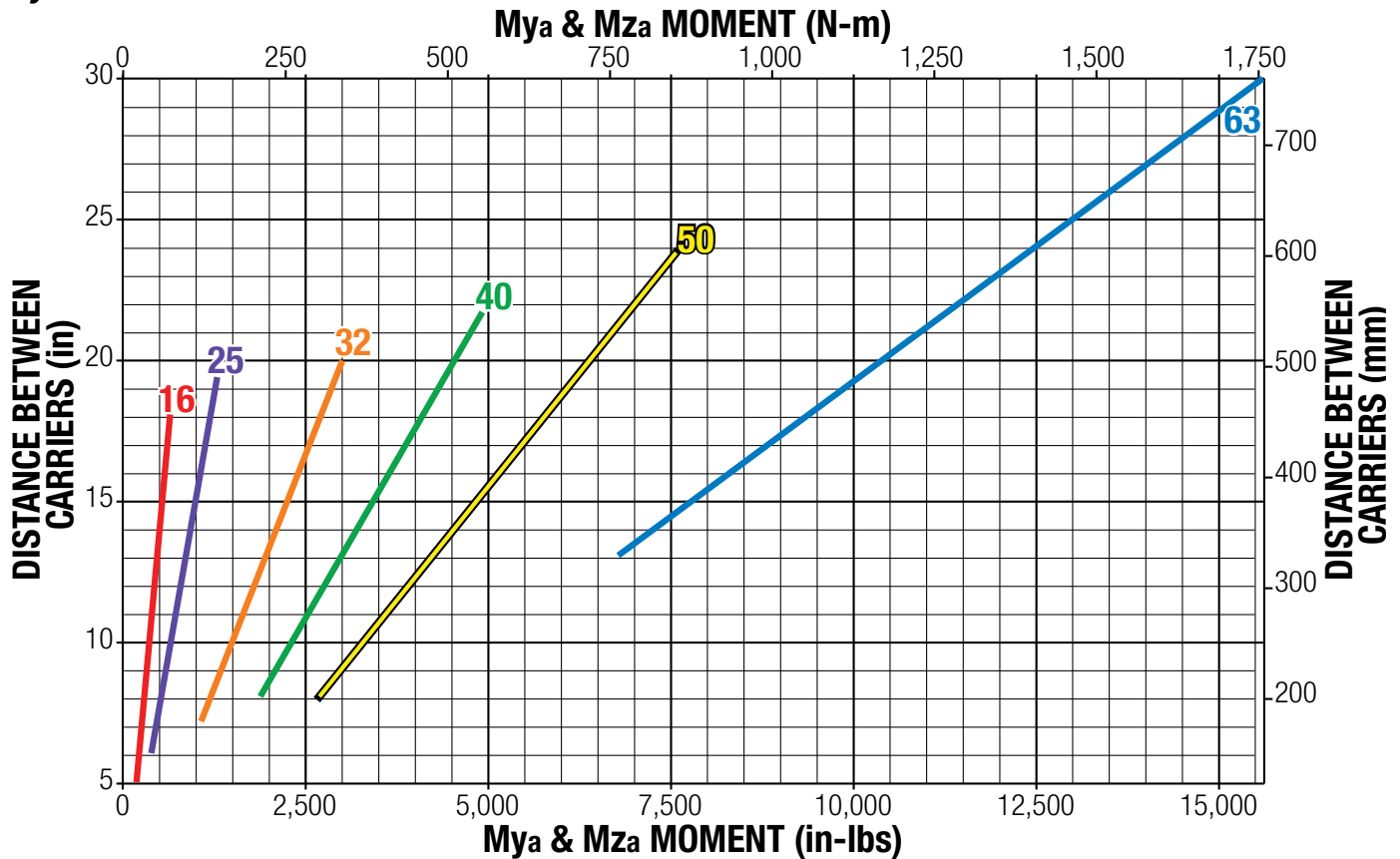

Ratings were calculated with the following conditions:

- 1.) Coupling between carriers is rigid.
- 2.) Load is equally distributed between carriers.

- 3.) Coupling device applies no misaligned loads to carriers.

STANDARD

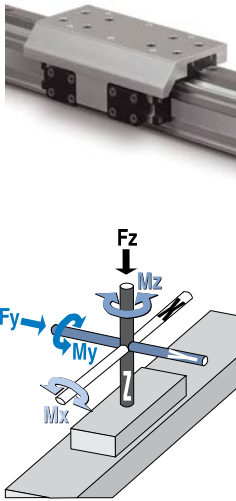

BORE			MAXIMUM BENDING MOMENTS			MAX. LOAD		THRUST (at 100 PSI)
			M_x	M_y	M_z	F_y	F_z	
1 6	Inch	0.63 in	39 in-lbs	339 in-lbs	339 in-lbs	217 lbf	217 lbf	30.7 lbf
	Metric	16 mm	4.5 N-m	38.3 N-m	38.3 N-m	966 N	966 N	136 N
2 5	Inch	1.00 in	126 in-lbs	502 in-lbs	377 in-lbs	449 lbf	449 lbf	78.5 lbf
	Metric	25 mm	14.3 N-m	56.7 N-m	42.6 N-m	1,996 N	1,996 N	349 N
3 2	Inch	1.25 in	226 in-lbs	1,344 in-lbs	1,344 in-lbs	569 lbf	569 lbf	123 lbf
	Metric	32 mm	25.6 N-m	152 N-m	152 N-m	2,531 N	2,531 N	546 N
4 0	Inch	1.50 in	600 in-lbs	1,913 in-lbs	1,913 in-lbs	736 lbf	736 lbf	177 lbf
	Metric	38 mm	67.8 N-m	216 N-m	216 N-m	3,274 N	3,274 N	786 N
5 0	Inch	2.00 in	811 in-lbs	3,483 in-lbs	3,483 in-lbs	1,014 lbf	1,014 lbf	314 lbf
	Metric	50 mm	91.7 N-m	394 N-m	394 N-m	4,510 N	4,510 N	1,397 N
6 3	Inch	2.50 in	1,019 in-lbs	5,339 in-lbs	5,339 in-lbs	1,292 lbf	1,292 lbf	491 lbf
	Metric	64 mm	115 N-m	603 N-m	603 N-m	5,745 N	5,745 N	2,184 N

! NOTE: Mating surface of component mounted to carrier must maintain a flatness of at least 0.0015" (0.040 mm)

! Ratings are the maximum values for shock-free, vibration-free operation in a typical industrial environment. Contact Tolomatic for assistance in selecting the most appropriate actuator for your application.



tolomatic.com/ask
Technical support
before and after
purchase

The moment and load capacity of the actuator's bearing system is based on an L10 life of 200,000,000 linear inches of travel. Life of the actuator will vary for each application depending on the combined loads, motion parameters and operating conditions. The load factor (L_F) ratios for each application must not exceed a value of 1 (as calculated below). Exceeding a load factor of 1 will diminish the actuator's rated life.

$$L_F = \frac{M_x}{M_{x_{max}}} + \frac{M_y}{M_{y_{max}}} + \frac{M_z}{M_{z_{max}}} + \frac{F_y}{F_{y_{max}}} + \frac{F_z}{F_{z_{max}}} \leq 1$$

With combined loads, L_F must not exceed the value 1.

SPEED FACTOR

FOR APPLICATIONS WITH HIGH SPEED OR SIGNIFICANT SHOCK AND VIBRATION: Calculated values of loads and bending moments must be increased by speed factor from the graph at right to obtain full rated life of profiled rail bearing system.

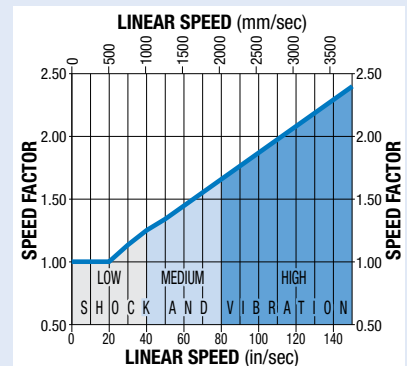

PROFILED RAIL LUBRICATION

Proper lubrication of profiled rail bearing system is essential for normal operation and achievement of full rated life of MX--P actuators. Lubrication should be performed at intervals of 4,000,000 inches of travel or once every year, whichever occurs first. **However, operating conditions such as high speed or significant shock and vibration may require more frequent lubrication.** Please consult Tolomatic for recommendations.

Recommended grease types:

1. Refined mineral oil-based multi-purpose grease with lithium thickening agent.
2. High-grade synthetic oil-based grease with urea thickening agent.

DW AUXILIARY CARRIER

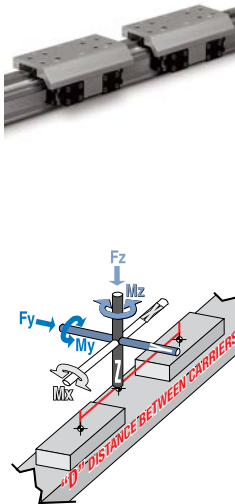

BORE			"D" MIN	MAXIMUM BENDING MOMENTS*			MAX. LOAD		THRUST (at 100 PSI)
				MxA	MyA	MzA	FzA	FyA	
16	Inch	0.63 in	5.0 in	79 in-lbs	620 in-lbs	620 in-lbs	434 lbf	434 lbf	30.7 lbf
	Metric	16 mm	127 mm	8.9 N-m	70.1 N-m	70.1 N-m	1,932 N	1,932 N	136 N
25	Inch	1.00 in	6.0 in	252 in-lbs	1,610 in-lbs	1,610 in-lbs	898 lbf	898 lbf	78.5 lbf
	Metric	25 mm	152 mm	28.5 N-m	182 N-m	182 N-m	3,993 N	3,993 N	349 N
32	Inch	1.25 in	7.0 in	453 in-lbs	2,202 in-lbs	2,202 in-lbs	1,138 lbf	1,138 lbf	123 lbf
	Metric	32 mm	178 mm	51.1 N-m	249 N-m	249 N-m	5,063 N	5,063 N	546 N
40	Inch	1.50 in	8.5 in	1,208 in-lbs	3,601 in-lbs	3,601 in-lbs	1,472 lbf	1,472 lbf	177 lbf
	Metric	38 mm	216 mm	137 N-m	407 N-m	407 N-m	6,549 N	6,549 N	786 N
50	Inch	2.00 in	8.6 in	1,623 in-lbs	4,966 in-lbs	4,966 in-lbs	2,028 lbf	2,028 lbf	314 lbf
	Metric	50 mm	218 mm	183 N-m	561 N-m	561 N-m	9,020 N	9,020 N	1,397 N
63	Inch	2.50 in	13.0 in	2,038 in-lbs	9,508 in-lbs	9,508 in-lbs	2,583 lbf	2,583 lbf	491 lbf
	Metric	64 mm	330 mm	230 N-m	1,074 N-m	1,074 N-m	11,490 N	11,490 N	2,184 N

*At minimum "D" distance between carriers see graph below for other distances

With combined loads, L_f must not exceed the value 1.

$$L_f = \frac{M_x}{M_{x_{max}}} + \frac{M_y}{M_{y_{max}}} + \frac{M_z}{M_{z_{max}}} + \frac{F_y}{F_{y_{max}}} + \frac{F_z}{F_{z_{max}}} \leq 1$$

! Ratings are the maximum values for shock-free, vibration-free operation in a typical industrial environment. Contact Tolomatic for assistance in selecting the most appropriate actuator for your application.

! NOTE: Mating surface of component mounted to carrier must maintain a flatness of at least 0.0015" (0.040 mm)

Mya & Mza vs. DISTANCE

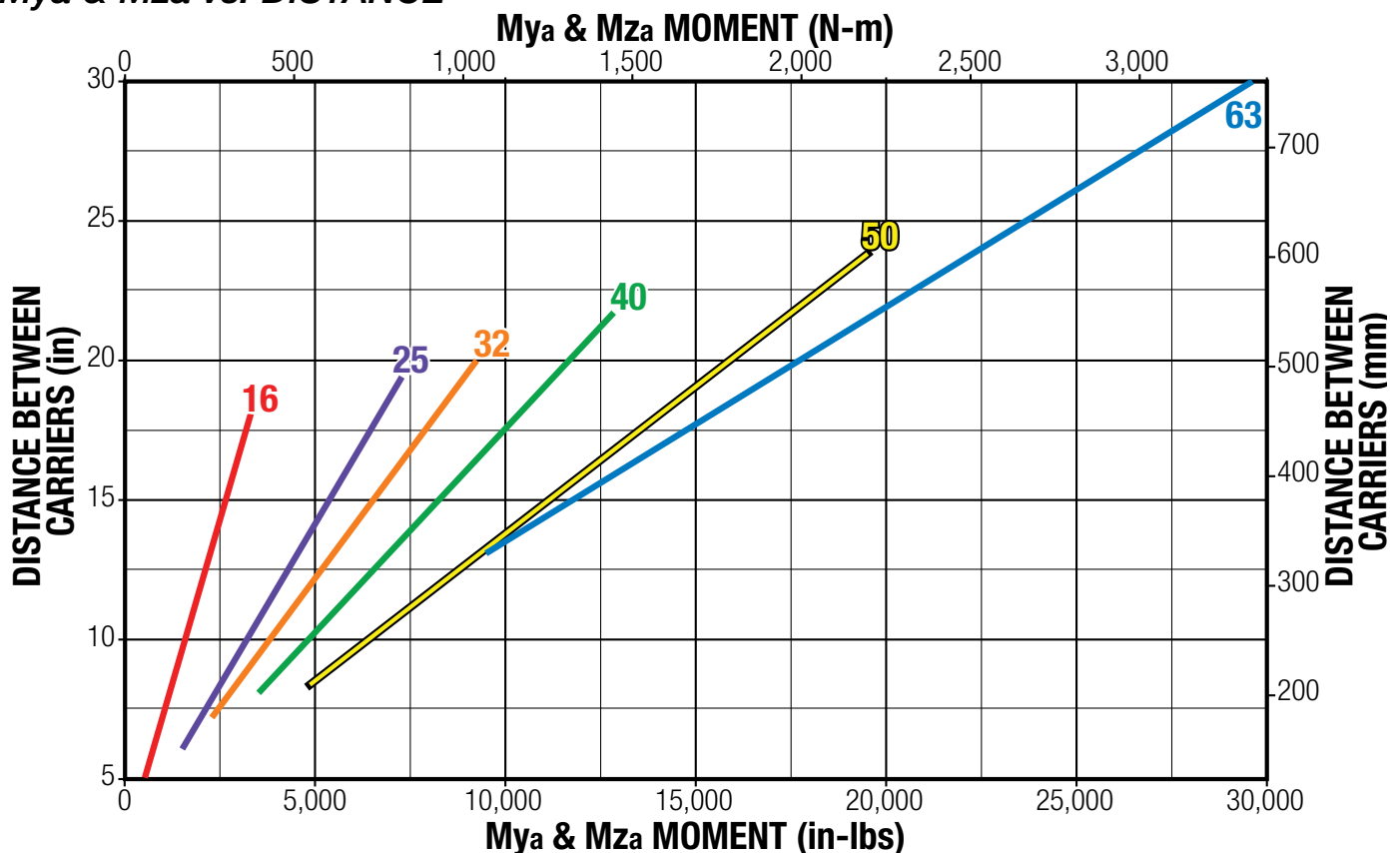

Ratings were calculated with the following conditions:

- 1.) Coupling between carriers is rigid.
- 2.) Load is equally distributed between carriers.
- 3.) Coupling device applies no misaligned loads to carriers.

LOAD DEFLECTION

DEFLECTION ABOUT X AXIS

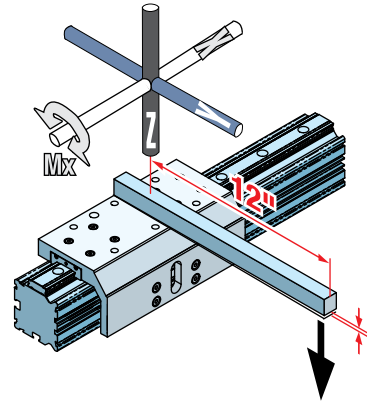
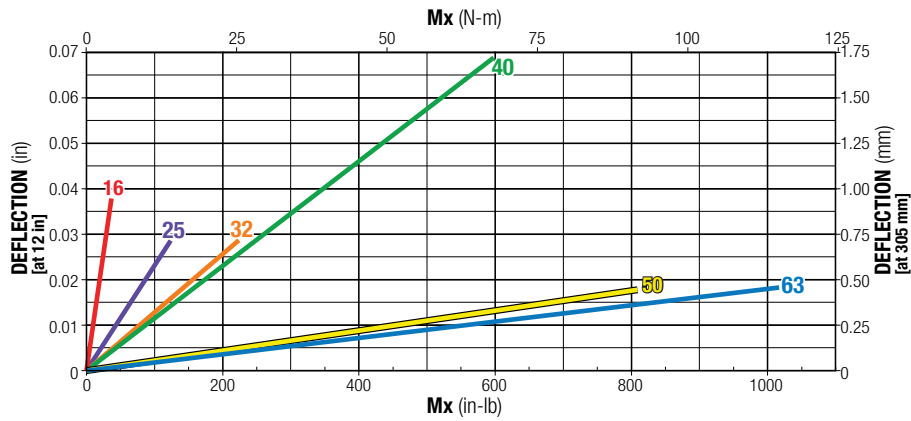

DEFLECTION ABOUT Y AXIS

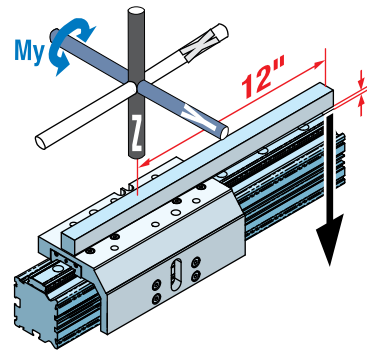
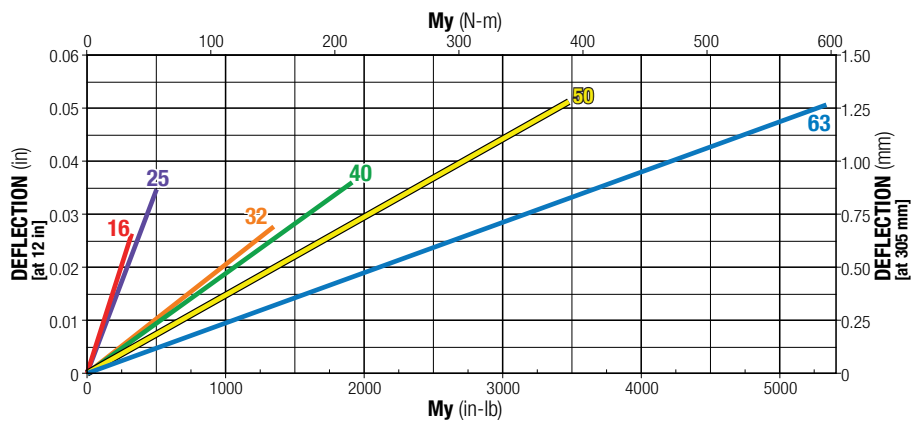

DEFLECTION ABOUT Z AXIS

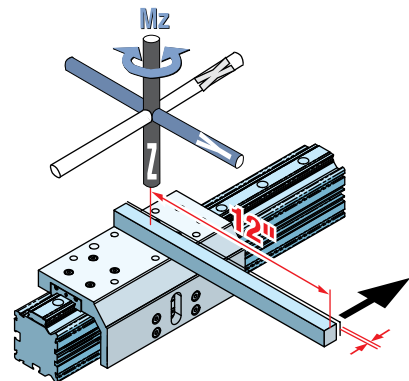
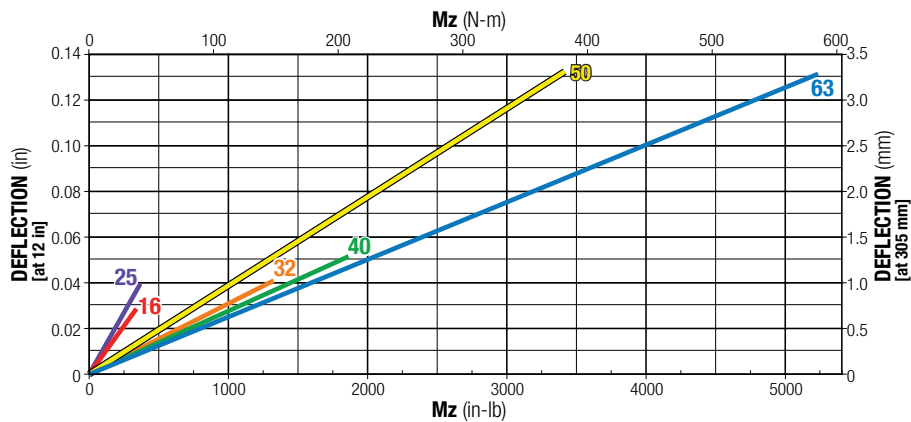

DEFLECTION TESTING WAS DONE UNDER THESE CRITERIA:

- 1.) Actuator was properly mounted with distance between mounting plates within recommendations (see Tube Clamp Requirements page MXP_20)
- 2.) Deflection was measured at 12" from center of carrier as shown

SPECIFICATIONS

		SIZE	16	25	32	40	50	63	
ACTUAL BORE SIZE		in	0.63	1.00	1.25	1.50	2.00	2.50	
		mm	16	25	32	38	50	64	
BASE WEIGHT	N INTERNAL BEARING	lb	0.73	1.70	3.58	5.57	11.07	22.59	
		kg	0.33	0.77	1.62	2.53	5.02	10.25	
	S SOLID BEARING	lb	1.07	2.30	4.68	7.64	14.03	30.78	
		kg	0.48	1.04	2.12	3.47	6.36	13.96	
	P PROFILED RAIL	lb	1.25	2.94	5.89	9.91	17.22	31.64	
		kg	0.57	1.33	2.67	4.5	7.81	14.35	
WEIGHT PER UNIT OF STROKE	N INTERNAL & S SOLID	lb/in	0.082	0.134	0.233	0.306	0.513	0.879	
		kg/mm	0.0015	0.0024	0.0042	0.0055	0.0092	0.0157	
	P PROFILED RAIL	lb/in	0.102	0.192	0.316	0.491	0.701	1.153	
		kg/mm	0.0018	0.0034	0.0056	0.0088	0.0125	0.0206	
MAXIMUM STROKE LENGTH		in	206	206	205	203	203	103	
		mm	5232	5232	5207	5156	5156	2616	
AUXILIARY CARRIER; MIN. "D" BETWEEN CARRIERS		in	5.00	6.00	7.00	8.50	8.60	13.00	
		mm	127.0	152.4	177.8	215.9	218.4	330.2	
MAXIMUM OPERATING PRESSURE		PSI	100						
		bar	6.9						
TEMPERATURE RANGE		°F	20 to 140						
		°C	-7 to 60						

TIPS FOR MAXIMIZING BAND CYLINDER LIFE

TO GET THE MOST LIFE OUT OF YOUR MXP BAND CYLINDER FOLLOW THESE SIMPLE GUIDELINES WHEN SIZING A BAND CYLINDER FOR AN APPLICATION.

Four factors that affect the life of a band cylinder are **Load, Speed, Environment and Deceleration**. The following tips will help you select the appropriate band cylinder for a specific application's loads and speeds to maximize actuator life.

1 LOAD: KEEP THE LOAD FACTOR LESS THAN 1

Applications with multiple loads put additional stress on the band cylinder's bearing system. It is important to account for all these loads to make sure the bearing system is not overloaded. Both static and dynamic loads need to be addressed.

The formula below can be used to calculate the load factor:

$$L_f = \frac{M_x}{M_{x_{max}}} + \frac{M_y}{M_{y_{max}}} + \frac{M_z}{M_{z_{max}}} + \frac{F_y}{F_{y_{max}}} + \frac{F_z}{F_{z_{max}}} \leq 1$$

2 SPEED: REDUCE SPEEDS

High speeds and cycle rates stress the band cylinder's guidance system more than slower applications. Keeping speeds reduced will optimize the life of the actuator.

3 ENVIRONMENT: KEEP CONTAMINATION OFF BAND AND MOVING SURFACES

Contamination will decrease band cylinder service life. Service life can be improved by orienting the band and bearing system 180 degrees from the contamination source. For instance, if solid particulates are falling on the actuator, it is best to try to orient the band cylinder so that the band and bearing system are shielded from the particulates.

4 DECELERATION: DECELERATE WITH SHOCK ABSORBERS

Shock absorbers provide the most controlled and reliable deceleration at the end of stroke. Stopping in a controlled fashion will significantly decrease the inertia loads on the carrier bearings, extending cylinder life. The best location for shock absorbers is at the center of gravity of the load.

CUSHION & SHOCK ABSORBER PERFORMANCE

MXP16 (ALL BEARINGS)

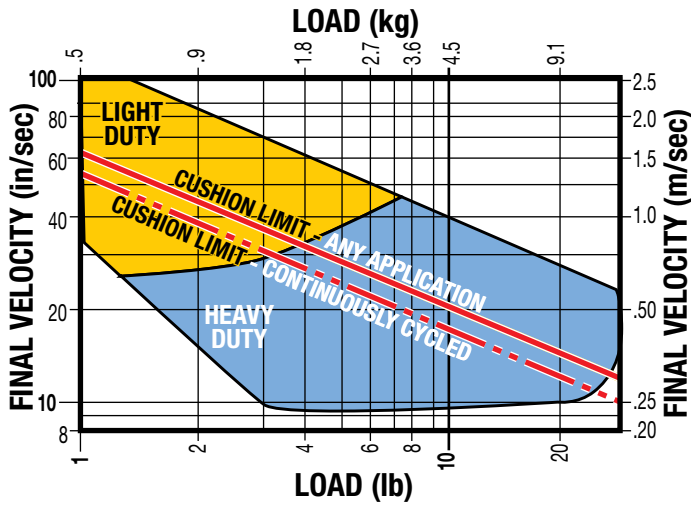

MXP25 (ALL BEARINGS)

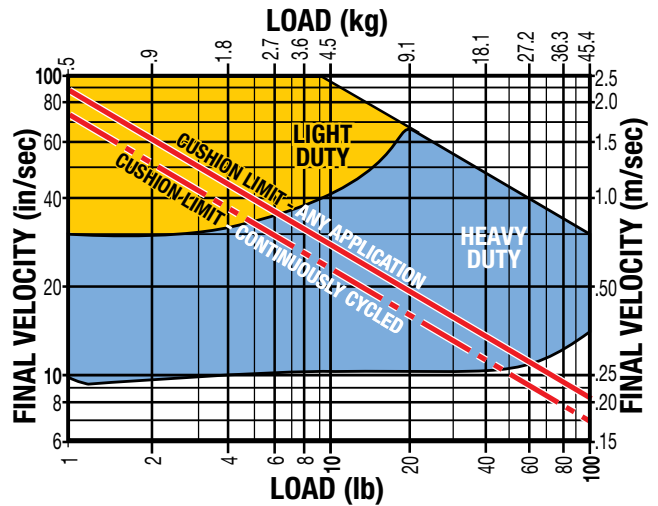

MXP32 (ALL BEARINGS)

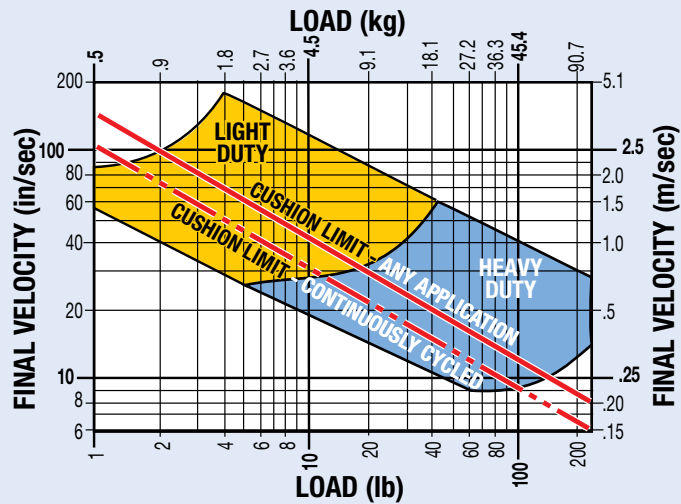

MXP40 (ALL BEARINGS)

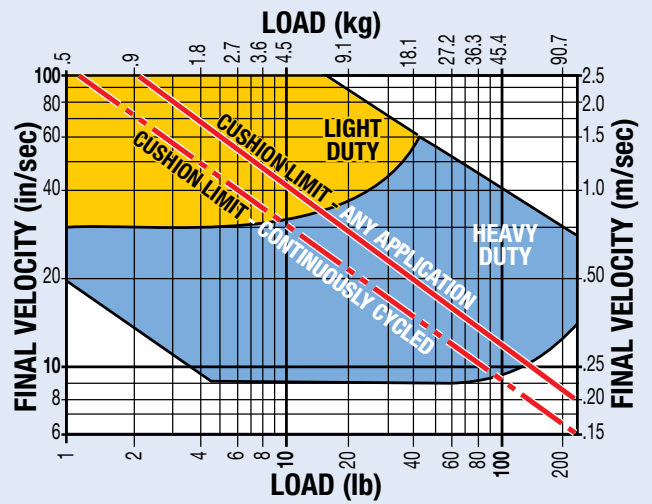

MXP50 (ALL BEARINGS)

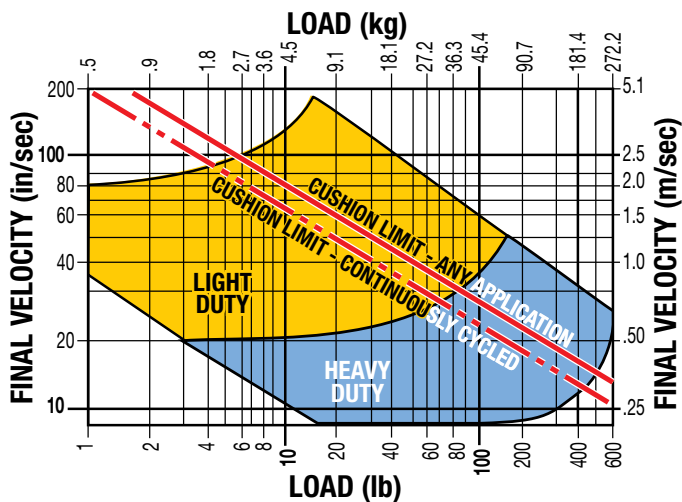

MXP63 (ALL BEARINGS)

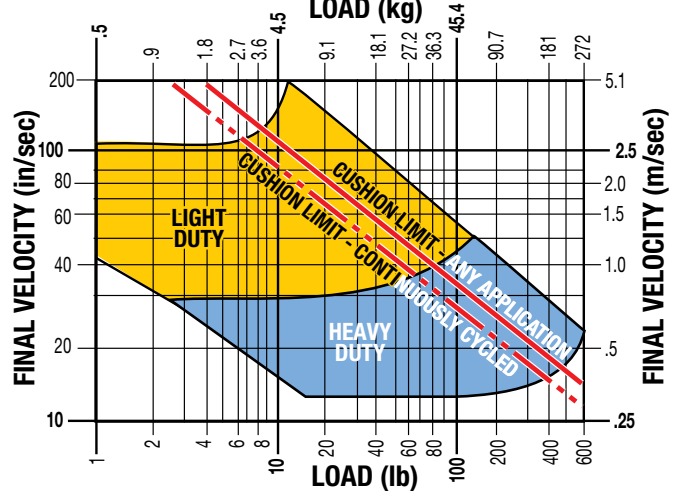

NOTE: If final (impact) velocity cannot be calculated directly, a reasonable guideline to use is 2X average velocity.

⚠ NOTE: When 2 shock absorbers are ordered, the MXP will be assembled with NO internal cushion seals.

TUBE CLAMP REQUIREMENTS

N - INTERNAL BEARING

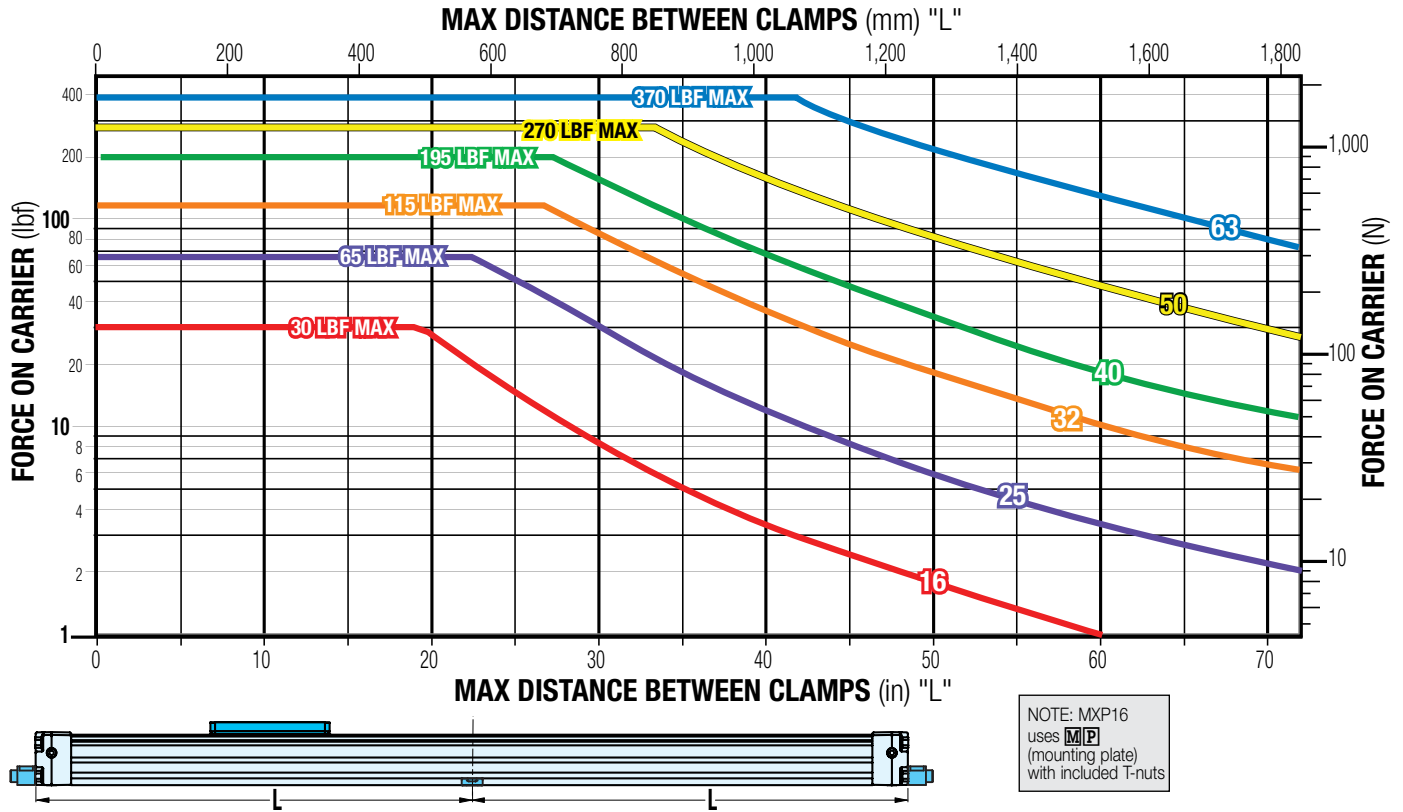

S - SOLID BEARING

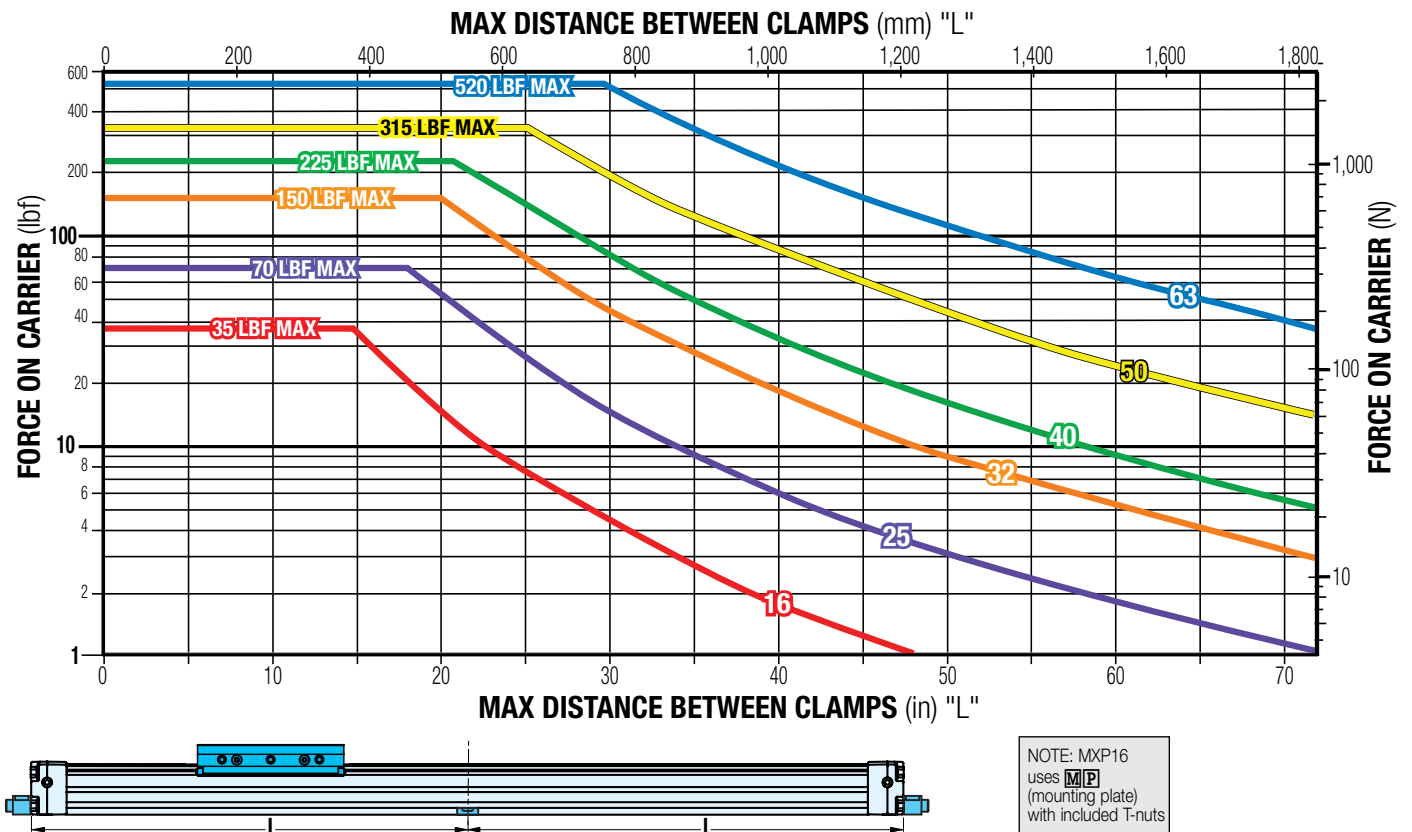

TUBE CLAMP REQUIREMENTS

P - PROFILED RAIL

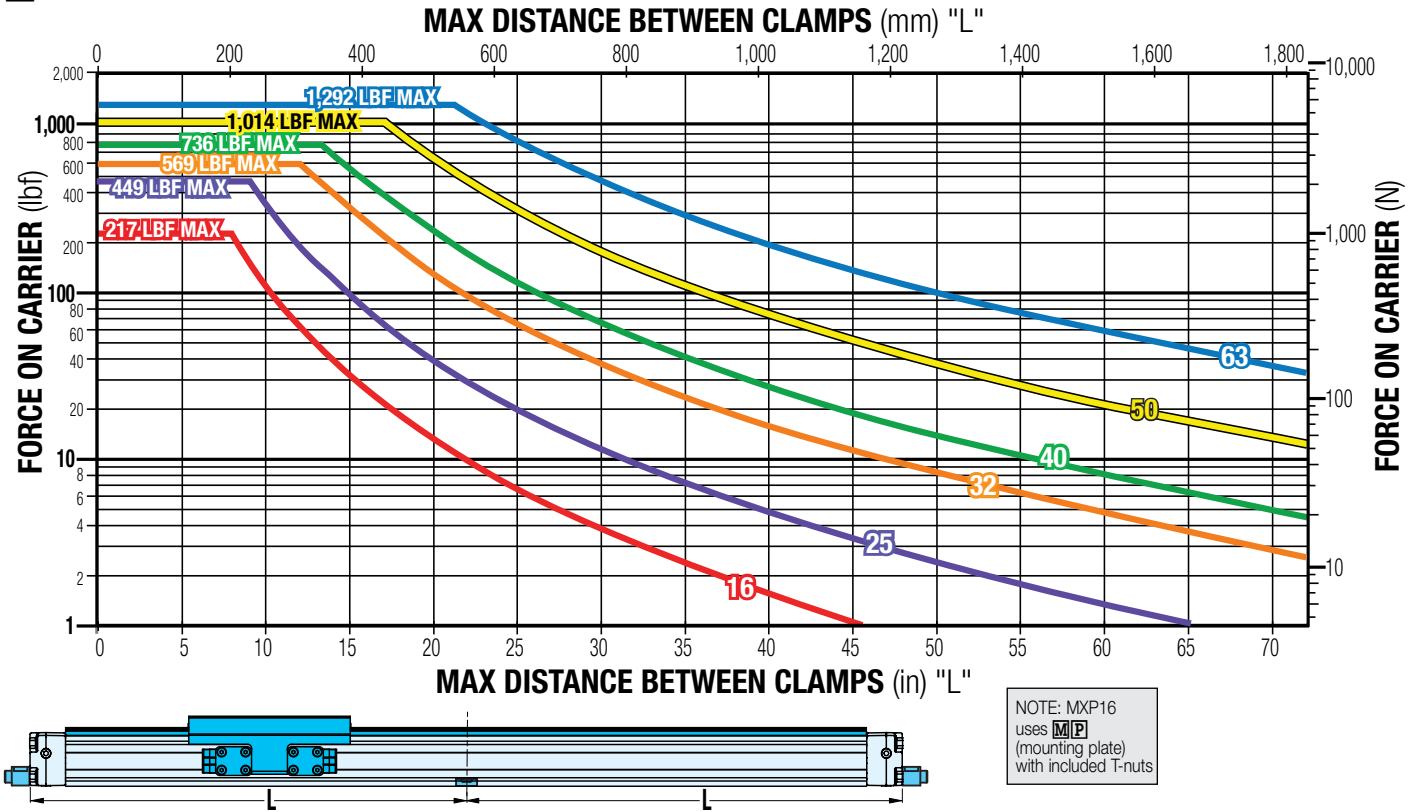

N-INTERNAL BEARING ACTUATOR DIMENSIONS

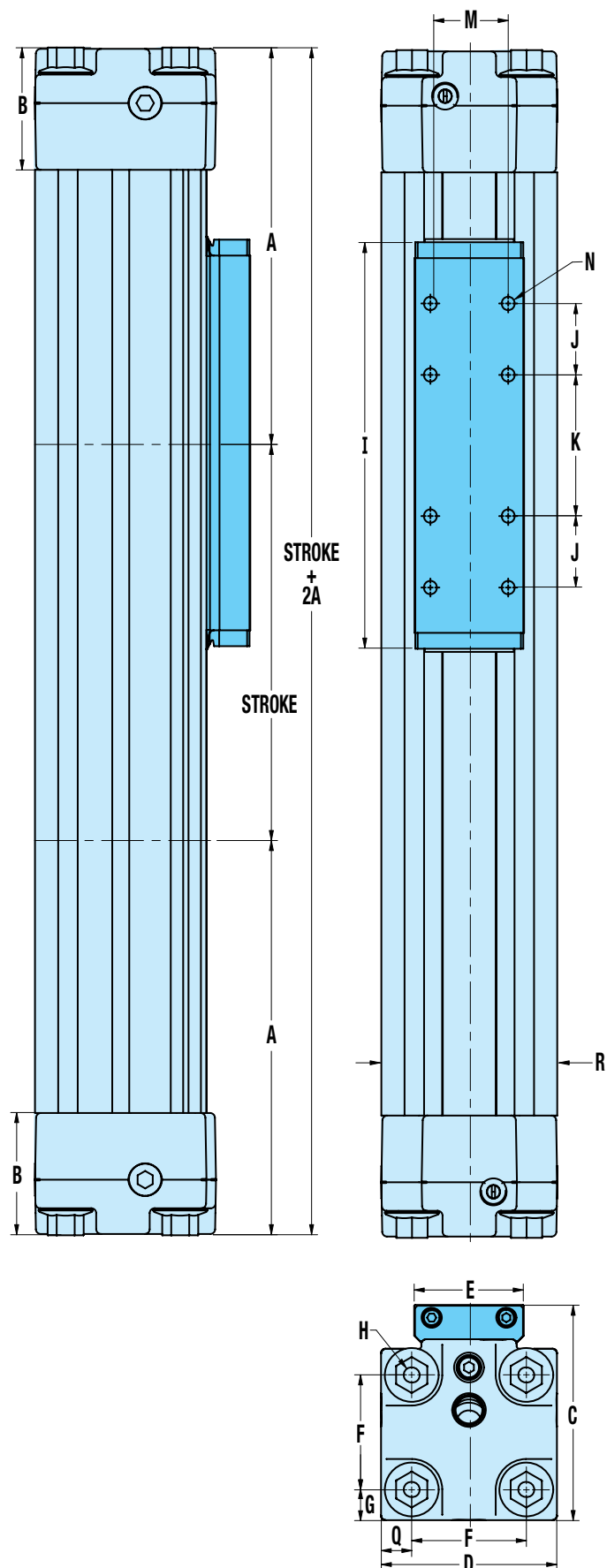

	MXP16	MXP25	MXP32	MXP40	MXP50	MXP63
A	3.13	3.94	4.90	5.82	6.29	8.45
<i>mm</i>	79.6	100.2	124.5	147.7	159.8	214.5
B	0.55	1.11	1.50	1.50	1.97	1.97
<i>mm</i>	14.0	28.3	38.1	38.0	50.0	50.0
C	1.55	2.07	2.67	2.98	3.86	4.76
<i>mm</i>	39.3	52.6	67.8	75.8	98.1	120.8
D	1.18	1.65	2.18	2.52	3.01	3.94
<i>mm</i>	30.0	42.0	55.4	64.0	78.7	100.0
E	0.83	0.83	1.36	1.61	2.13	2.44
<i>mm</i>	21.0	21.0	34.5	41.0	54.0	62.0
F	0.85	1.10	1.42	1.81	2.25	2.87
<i>mm</i>	21.5	27.9	36.1	46.0	57.2	73.0
G	0.17	0.25	0.38	0.35	0.43	0.53
<i>mm</i>	4.3	6.3	9.7	9.0	10.8	13.5
H	#8-32 (8)	#10-24 (8)	1/4-20 (8)	1/4-20 (8)	5/16-18 (8)	5/16-18 (8)
<i>mm</i>	M4x0.7 (8)	M5x0.8 (8)	M6x1.0 (8)	M6x1.0 (8)	M8x1.25 (8)	M8x1.25 (8)
I	3.78	4.45	5.04	5.87	6.57	9.69
<i>mm</i>	96.0	113.0	128.0	149.0	166.8	246.0
J	0.59	0.79	0.89	0.63	1.13	1.18
<i>mm</i>	15.0	20.0	22.5	15.9	28.6	30.0
K	1.18	1.57	1.75	3.00	2.25	4.33
<i>mm</i>	30.0	40.0	44.5	76.2	57.2	110.0
M	0.63	0.59	0.96	1.05	1.50	1.69
<i>mm</i>	16.0	15.0	24.5	26.7	38.1	43.0
N	#6-32 (8)	#8-32 (8)	#10-32 (8)	1/4-20 (8)	5/16-18 (8)	3/8-16 (8)
<i>mm</i>	M3x0.5 (8)	M4x0.7 (8)	M5x0.8 (8)	M6x1.0 (8)	M8x1.25 (8)	M10x1.5 (8)
Q	0.17	0.28	0.38	0.35	0.43	0.53
<i>mm</i>	4.3	7.0	9.7	9.0	10.8	13.5
R	1.18	1.65	2.18	2.52	3.10	3.94
<i>mm</i>	30.00	42.00	55.37	64.00	78.74	100.00



DUAL END PORTING

16mm
BORE

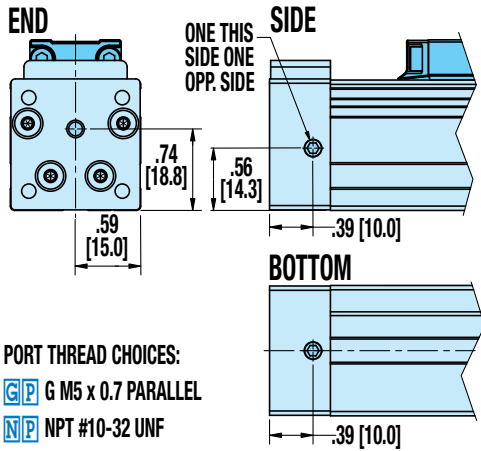

SINGLE-END PORTING

Not Available for 16mm BORE

25mm
BORE

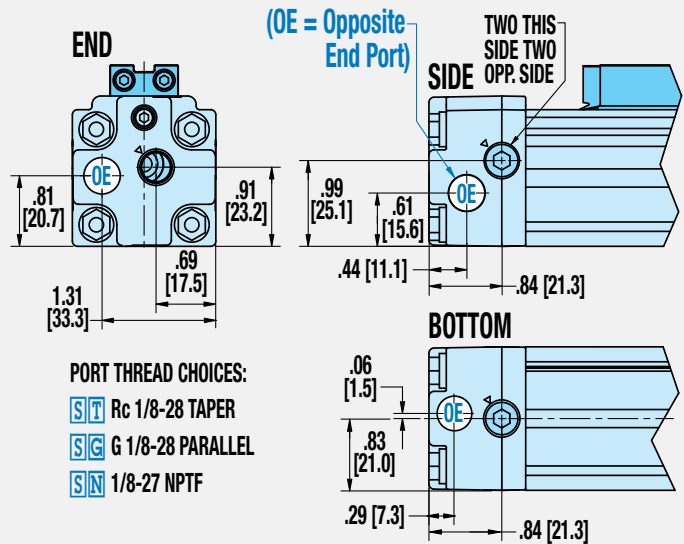
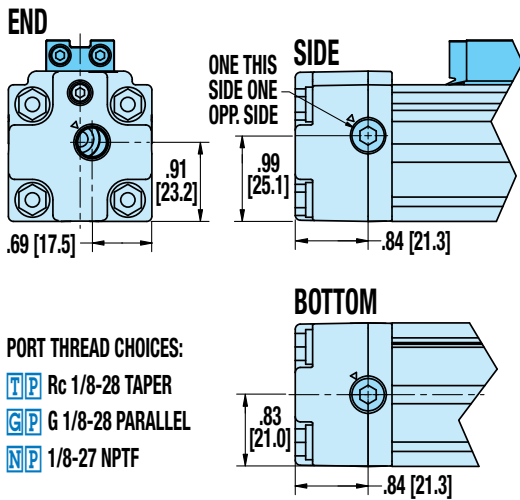

32mm
BORE

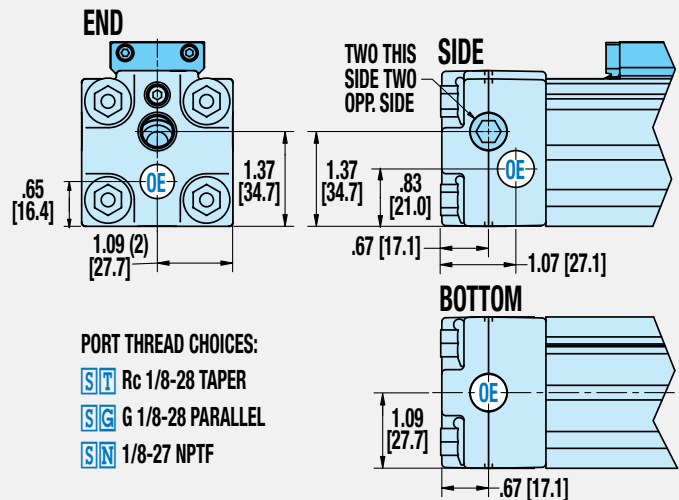
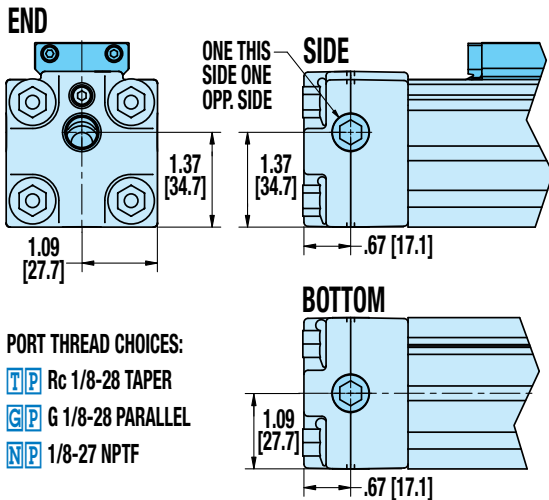

Dimensions in inches [brackets indicate dimensions in millimeters]

40mm
BORE

DUAL END PORTING

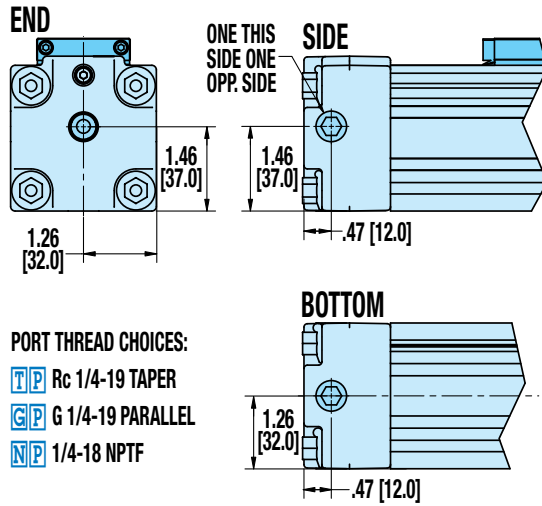

SINGLE-END PORTING

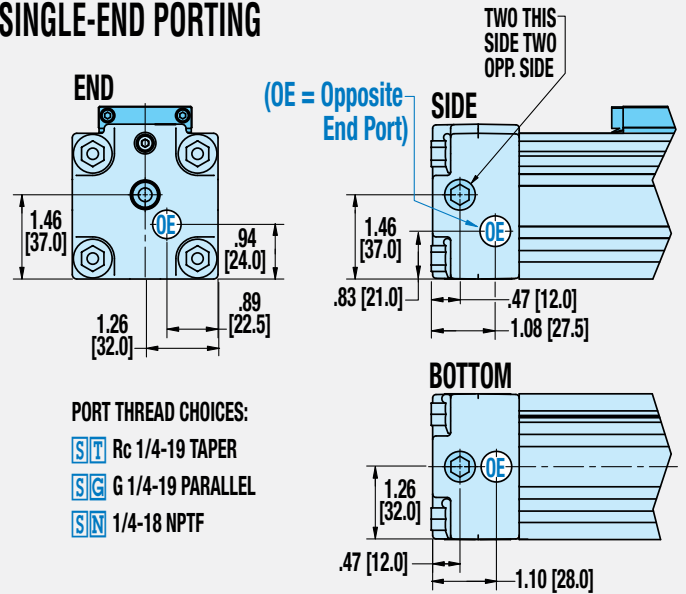

50mm
BORE

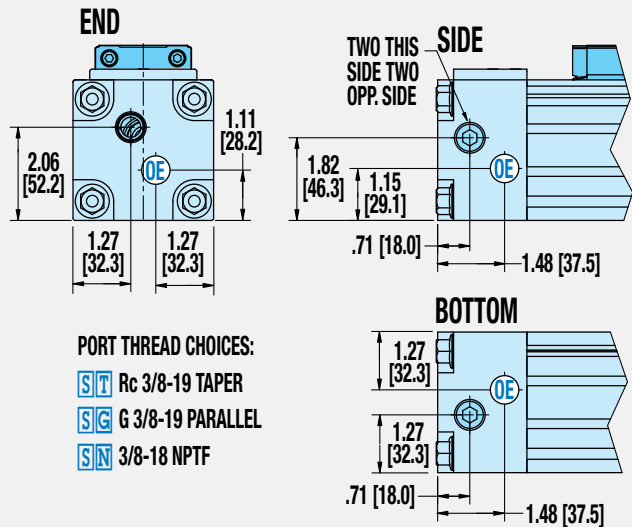
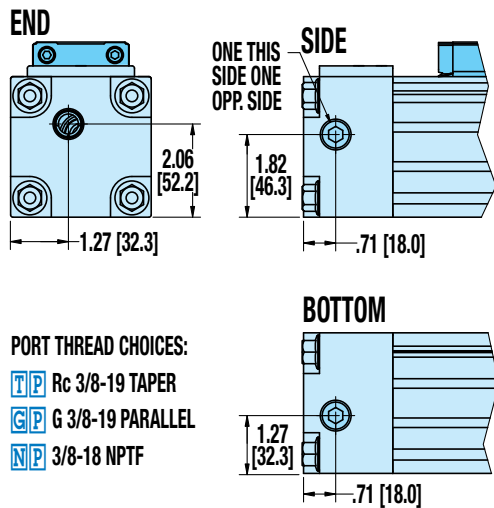

63mm
BORE

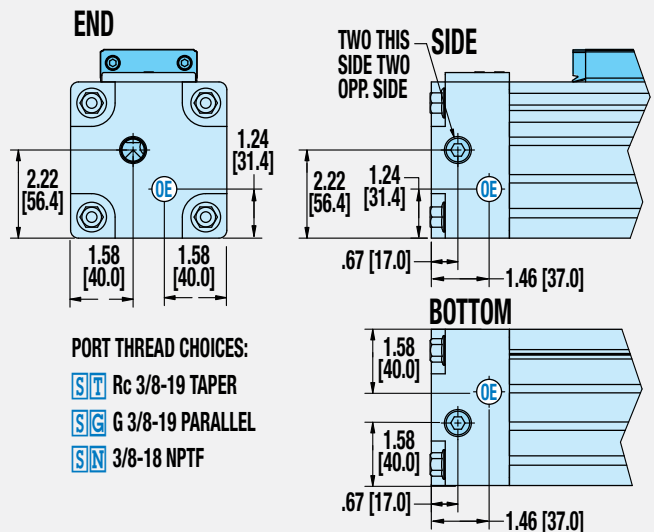
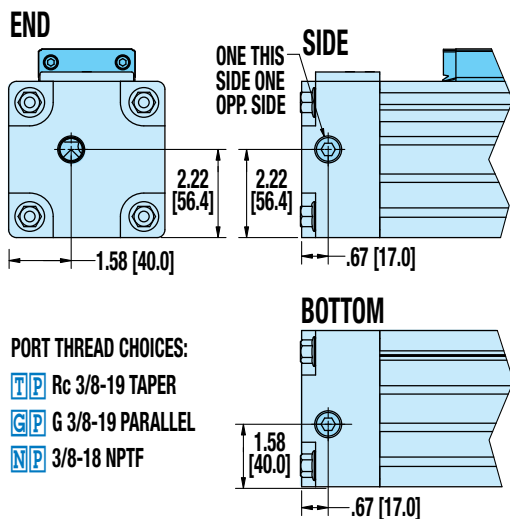

Dimensions in inches [brackets indicate dimensions in millimeters]



N-INTERNAL BEARING OPTION DIMENSIONS

AUXILIARY CARRIER, FLOATING MOUNT, FOOT MOUNT, TUBE CLAMPS

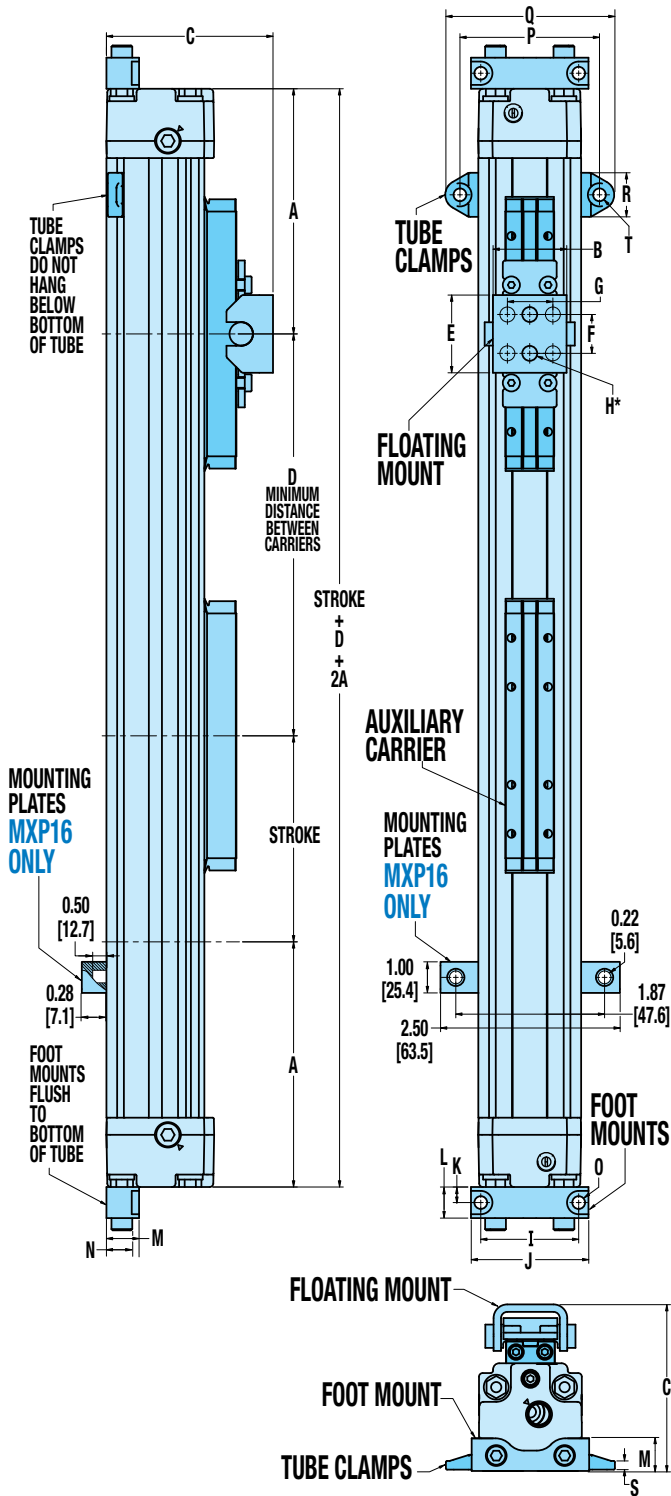

	MXP16	MXP25	MXP32	MXP40	MXP50	MXP63
A	3.13	3.94	4.90	5.82	6.29	8.45
<i>mm</i>	79.6	100.2	124.5	147.7	159.8	214.5
AUXILIARY CARRIER						
D	5.00	6.00	7.00	8.50	8.60	13.00
<i>mm</i>	127.0	152.4	177.8	215.9	218.4	330.0
FLOATING MOUNT						
B	1.27	1.19	2.08	2.55	3.24	3.15
<i>mm</i>	32.2	30.1	52.8	64.7	82.3	80.0
C	1.97	2.66	3.70	4.07	4.66	5.57
<i>mm</i>	50.1	67.5	94.1	103.3	118.4	141.6
E	0.90	1.25	1.50	1.50	3.94	5.20
<i>mm</i>	22.9	31.8	38.1	38.1	100.1	132.0
F	0.50	0.63	0.75	0.79	3.15	4.33
<i>mm</i>	12.7	15.9	19.1	20.0	80.0	110.0
G	-	-	1.00	1.38	-	1.69
<i>mm</i>	-	-	25.4	35.0	-	43.0
H*	0.17(2)	0.24(2)	0.28(4)	0.28(4)	0.36(2)	0.34(4)
<i>mm</i>	4.3(2)	6.1(2)	7.1(4)	7.1(4)	9.1(2)	8.7(4)
FOOT MOUNTS						
I	1.26	1.57	2.01	2.52	3.11	3.94
<i>mm</i>	32.0	40.0	51.0	64.0	78.9	100.0
J	1.57	1.89	2.36	2.91	3.67	4.72
<i>mm</i>	40.0	48.0	60.0	74.0	93.2	120.0
K	0.16	0.25	0.37	0.47	0.50	0.59
<i>mm</i>	4.0	6.4	9.5	12.0	12.7	15.0
L	0.31	0.50	0.75	0.94	1.00	1.18
<i>mm</i>	8.0	12.7	19.0	24.0	25.4	30.0
M	0.35	0.52	0.91	0.73	1.00	1.06
<i>mm</i>	8.9	13.3	23.0	18.5	25.4	27.0
N	-	0.41	0.71	0.45	0.69	0.65
<i>mm</i>	-	10.3	18.0	11.4	17.4	16.5
O	0.18	0.20	0.22	0.28	0.35	0.42
<i>mm</i>	4.6	5.2	5.5	7.1	9.0	10.7
TUBE CLAMPS						
P	-	2.24	2.92	3.26	3.84	5.19
<i>mm</i>	-	57.0	74.1	82.7	97.5	131.7
Q	-	2.72	3.44	3.81	4.39	5.93
<i>mm</i>	-	69.0	87.4	96.7	111.5	150.7
R	-	0.71	0.63	0.55	0.55	0.75
<i>mm</i>	-	18.0	16.0	14.0	14.0	19.0
S	-	0.14	0.17	0.15	0.15	0.24
<i>mm</i>	-	3.6	4.3	3.8	3.8	6.1
T	-	0.20	0.28	0.28	0.28	0.42
<i>mm</i>	-	5.2	7.1	7.1	7.1	10.7

*MXP16, 25 & 50 use 2 center holes,
MXP32, 40 & 63 use 4 corner holes

NOTE: Auxiliary carrier is N-Internal Bearing carrier, see page MXP_21 for carrier size and mounting dimensions

N-INTERNAL BEARING OPTION DIMENSIONS

ADJUSTABLE AND FIXED SHOCK ABSORBERS

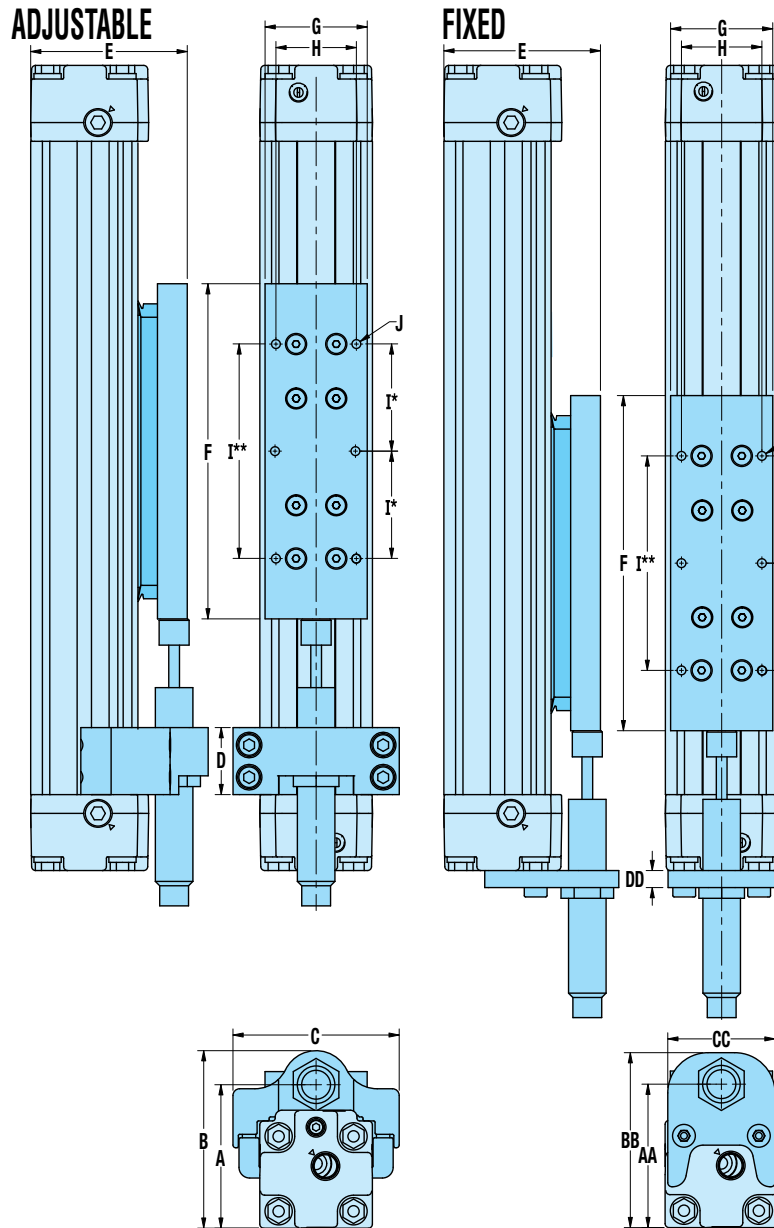

ADJUSTABLE SHOCK ABSORBER

	MXP16	MXP25	MXP32	MXP40	MXP50	MXP63
A	1.65	2.11	2.91	3.32	4.24	5.21
<i>mm</i>	42.0	53.5	73.8	84.4	107.6	132.4
B	1.97	2.61	3.35	3.87	4.87	5.91
<i>mm</i>	50.0	66.2	85.0	98.4	123.8	150.0
C	1.74	2.44	2.95	3.43	4.09	5.20
<i>mm</i>	44.3	62.0	74.9	87.0	103.9	132.0
D	0.71	0.98	1.25	0.98	1.22	1.26
<i>mm</i>	18.0	25.0	31.8	25.0	31.0	32.0

Stroke Adder: Adjustable Shock Absorber

	MXP16	MXP25	MXP32	MXP40	MXP50	MXP63
in	0.49	1.06	1.17	0.76	0.81	0.51
<i>mm</i>	12.4	26.8	29.8	19.3	20.5	13.0

NOTE: For each adjustable shock absorber ordered, add Stroke Adder value to required stroke to determine configured actuator stroke.

$$\text{Required Stroke} + \left(\frac{\text{Adj. Stroke}}{\text{Quantity}} \times \text{Shock Adder value} \right) = \text{Configured Actuator Stroke}$$

Example: MXP25N, 500mm stroke required, 2 adjustable shocks
 $500 + (2 \times 26.8) = 500 + 53.6 = 553.6\text{mm}$

SHOCK PLATE

	MXP16	MXP25	MXP32	MXP40	MXP50	MXP63
E	1.81	2.28	3.17	3.61	4.55	5.65
<i>mm</i>	46.0	57.9	80.5	91.8	115.6	143.4
F	3.86	4.92	5.20	6.72***	6.65	10.29****
<i>mm</i>	98.0	125.0	132.0	170.8***	168.8	261.4****
G	0.94	1.50	1.32	1.61	2.13	2.44
<i>mm</i>	24.0	38.1	33.5	41.0	54.0	62.0
H	0.63	1.18	0.96	1.05	1.50	1.69
<i>mm</i>	16.0	30.0	24.5	26.7	38.1	43.0
I*	0.89	1.57	-	-	-	-
<i>mm</i>	22.5	40.0	-	-	-	-
I**	-	-	1.75	3.00	2.25	4.33
<i>mm</i>	-	-	44.5	76.2	57.2	110.0
J	#8-32 (6)	#8-32 (6)	#10-32 (4)	1/4-20 (4)	5/16-18 (4)	3/8-16 (4)
<i>mm</i>	M4x0.8 (6)	M4x0.8 (6)	M5x0.8 (4)	M6x1.0 (4)	M8x1.25 (4)	M10x1.5 (4)

*MXP16 & 25 Shock plate has 6 mounting holes

**MXP32, 40, 50 & 63 Shock plate has 4 mounting holes

***MXP40 Shock Stop Plate has impact bolts. Actual plate length is 5.98" (152mm); Impact bolts, one on each end, add .74" (18.8mm) to total length

****MXP63 Shock Stop Plate has impact bolts. Actual plate length is 9.84" (250mm); Impact bolts, one on each end, add .45" (11.4mm) to total length

FIXED SHOCK ABSORBER

	MXP16	MXP25	MXP32	MXP40	MXP50	MXP63
AA	1.65	2.11	2.91	3.32	4.24	5.21
<i>mm</i>	42.0	53.5	73.8	84.4	107.6	132.3
BB	1.95	2.57	3.42	3.87	5.09	5.92
<i>mm</i>	49.5	65.3	86.8	98.4	129.2	150.3
CC	1.17	1.57	2.00	2.44	2.83	3.66
<i>mm</i>	29.8	40.0	50.8	62.0	72.0	93.0
DD	0.13	0.25	0.25	0.25	0.50	0.50
<i>mm</i>	3.3	6.4	6.4	6.4	12.7	12.7



S-SOLID BEARING ACTUATOR DIMENSIONS

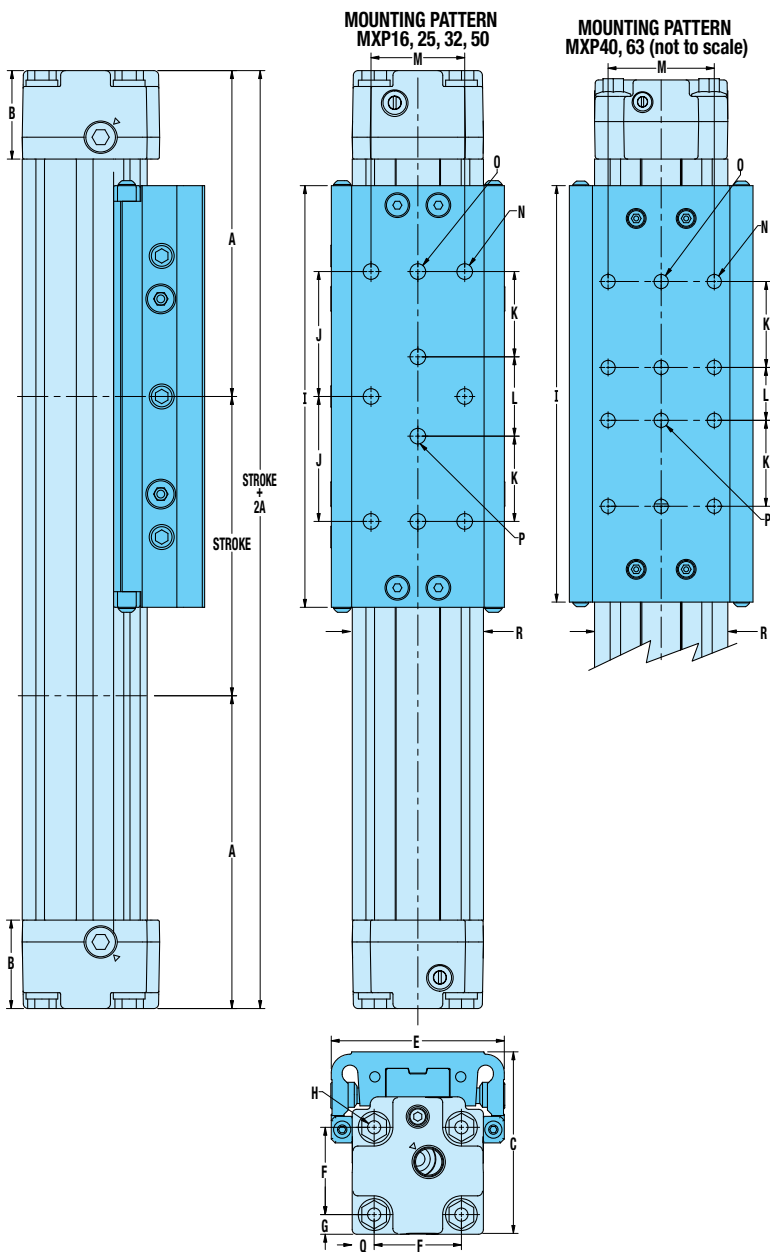

	MXP16	MXP25	MXP32	MXP40	MXP50	MXP63
A	3.13	3.94	4.90	5.82	6.29	8.45
<i>mm</i>	<i>79.6</i>	<i>100.2</i>	<i>124.5</i>	<i>147.7</i>	<i>159.8</i>	<i>214.5</i>
B	0.55	1.11	1.50	1.50	1.97	1.97
<i>mm</i>	<i>14.0</i>	<i>28.3</i>	<i>38.1</i>	<i>38.0</i>	<i>50.0</i>	<i>50.0</i>
C	1.80	2.30	3.06	3.51	4.44	5.48
<i>mm</i>	<i>45.8</i>	<i>58.4</i>	<i>77.8</i>	<i>89.2</i>	<i>112.8</i>	<i>139.1</i>
D	1.18	1.65	2.18	2.52	3.01	3.94
<i>mm</i>	<i>30.0</i>	<i>42.0</i>	<i>55.4</i>	<i>64.0</i>	<i>78.7</i>	<i>100.0</i>
E	1.58	2.18	2.86	3.47	4.01	5.59
<i>mm</i>	<i>40.1</i>	<i>55.4</i>	<i>72.6</i>	<i>88.2</i>	<i>104.1</i>	<i>142.0</i>
F	0.85	1.10	1.42	1.81	2.25	2.87
<i>mm</i>	<i>21.5</i>	<i>27.9</i>	<i>36.1</i>	<i>46.0</i>	<i>57.2</i>	<i>73.0</i>
G	0.17	0.25	0.38	0.35	0.43	0.53
<i>mm</i>	<i>4.3</i>	<i>6.3</i>	<i>9.7</i>	<i>9.0</i>	<i>10.8</i>	<i>13.5</i>
H	#8-32 (8)	#10-24 (8)	1/4-20 (8)	1/4-20 (8)	5/16-18 (8)	5/16-18 (8)
<i>mm</i>	<i>M4x0.7 (8)</i>	<i>M5x0.8 (8)</i>	<i>M6x1.0 (8)</i>	<i>M6x1.0 (8)</i>	<i>M8x1.25 (8)</i>	<i>M8x1.25 (8)</i>
I	4.12	5.31	6.02	7.87	7.91	12.11
<i>mm</i>	<i>104.6</i>	<i>135.0</i>	<i>153.0</i>	<i>200.0</i>	<i>200.8</i>	<i>307.5</i>
J	1.18	1.57	1.77	-	1.87	-
<i>mm</i>	<i>30.0</i>	<i>40.0</i>	<i>45.0</i>	<i>-</i>	<i>47.6</i>	<i>-</i>
K	-	1.07	1.10	1.63	1.25	1.50
<i>mm</i>	<i>-</i>	<i>27.3</i>	<i>28.0</i>	<i>41.3</i>	<i>31.8</i>	<i>38.1</i>
L	-	1.00	1.00	1.00	2.50	3.00
<i>mm</i>	<i>-</i>	<i>25.4</i>	<i>25.4</i>	<i>25.4</i>	<i>63.5</i>	<i>76.2</i>
M	1.18	1.18	1.73	2.01	2.59	3.25
<i>mm</i>	<i>30.0</i>	<i>30.0</i>	<i>44.0</i>	<i>51.0</i>	<i>65.8</i>	<i>82.6</i>
N	#8-32 (6)	1/4-20 (6)	1/4-20 (6)	5/16-18 (8)	3/8-16 (6)	3/8-16 (8)
<i>mm</i>	<i>M4x0.7 (6)</i>	<i>M6x1.0 (6)</i>	<i>M8x1.25 (6)</i>	<i>M8x1.25 (8)</i>	<i>M10x1.5 (6)</i>	<i>M10x1.5 (8)</i>
O	-	#10-32 (2)	1/4-20 (2)	5/16-18 (2)	3/8-16 (2)	3/8-16 (2)
<i>mm</i>	<i>-</i>	<i>M6x1.0 (2)</i>	<i>M8x1.25 (2)</i>	<i>M8x1.25 (2)</i>	<i>M10x1.5 (2)</i>	<i>M10x1.5 (2)</i>
P	-	1/4-20 (2)	1/4-20 (2)	1/4-20 (2)	3/8-16 (2)	3/8-16 (2)
<i>mm</i>	<i>-</i>	<i>M6x1.0 (2)</i>	<i>M8x1.25 (2)</i>	<i>M8x1.25 (2)</i>	<i>M10x1.5 (2)</i>	<i>M10x1.5 (2)</i>
Q	0.17	0.28	0.38	0.35	0.43	0.53
<i>mm</i>	<i>4.3</i>	<i>7.0</i>	<i>9.7</i>	<i>9.0</i>	<i>10.8</i>	<i>13.5</i>
R	1.18	1.65	2.18	2.52	3.10	3.94
<i>mm</i>	<i>30.00</i>	<i>42.00</i>	<i>55.37</i>	<i>64.00</i>	<i>78.74</i>	<i>100.00</i>

DUAL END PORTING

16mm
BORE

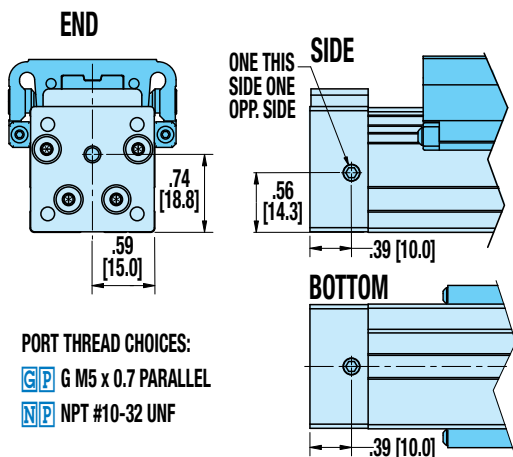

SINGLE-END PORTING

Not Available for 16mm BORE

25mm
BORE

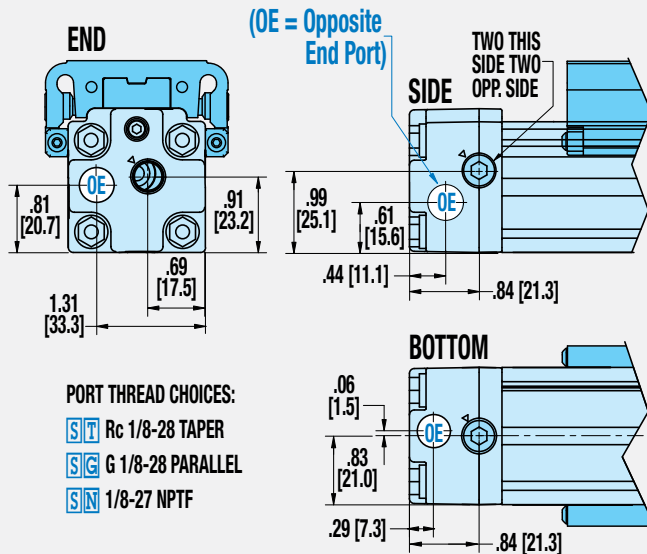
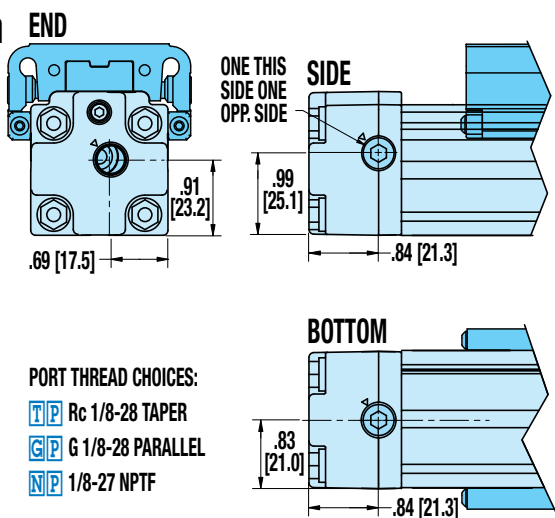

32mm
BORE

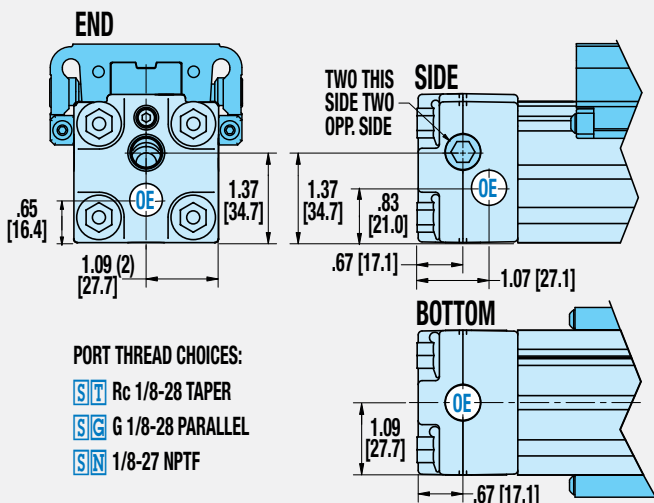
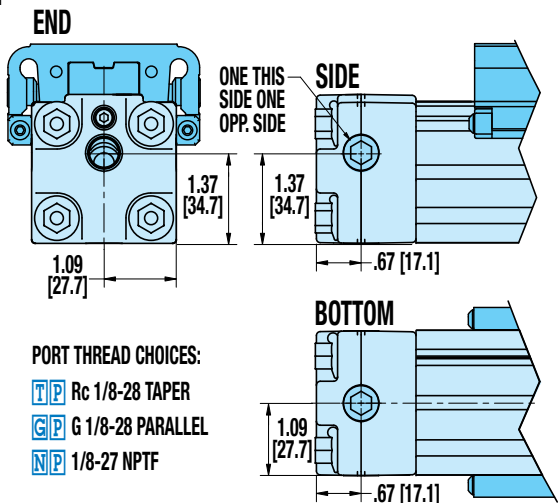

Dimensions in inches [brackets indicate dimensions in millimeters]

S-SOLID BEARING PORTING DIMENSIONS MXP40S, MXP50S, MXP63S

DUAL END PORTING

40mm BORE END

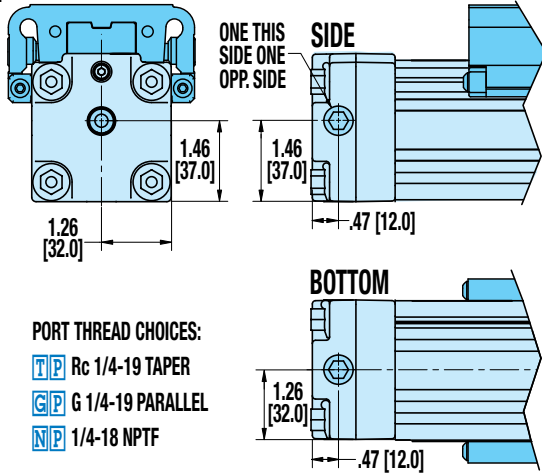

SINGLE-END PORTING

END

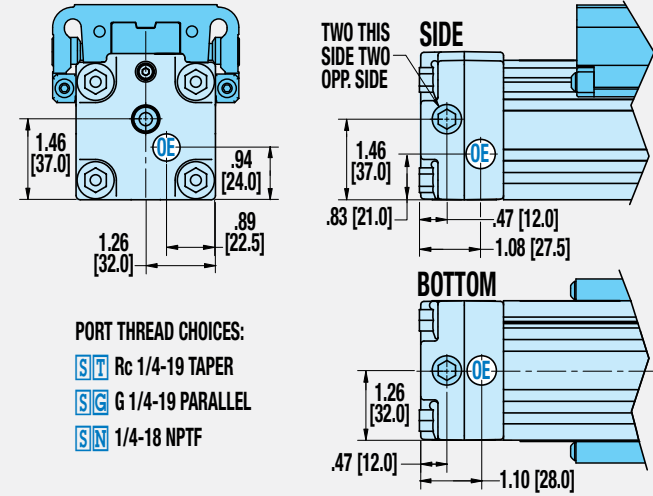

50mm BORE END

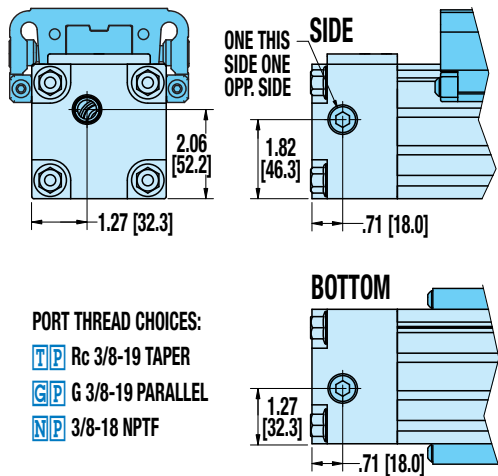

END

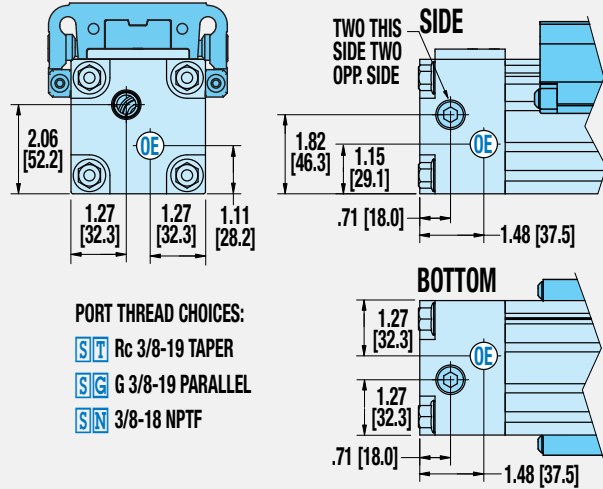

63mm BORE END

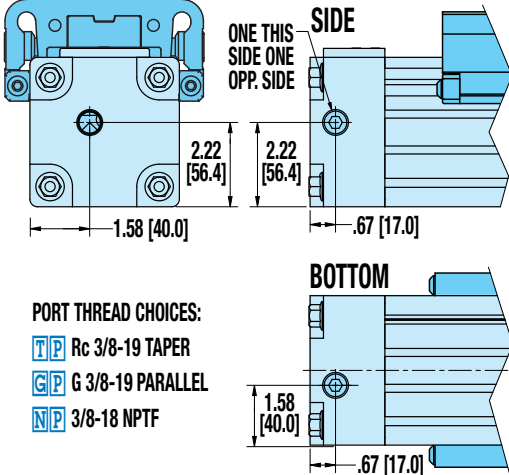

END

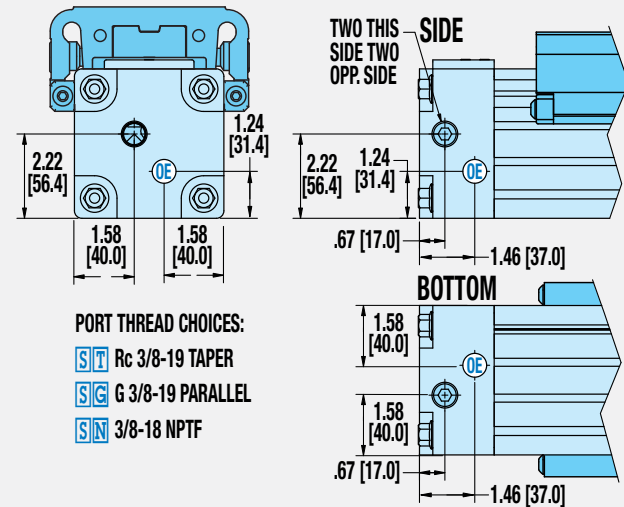

Dimensions in inches [brackets indicate dimensions in millimeters]

S-SOLID BEARING OPTION DIMENSIONS

AUXILIARY CARRIER, FLOATING MOUNT, FOOT MOUNT, TUBE CLAMPS

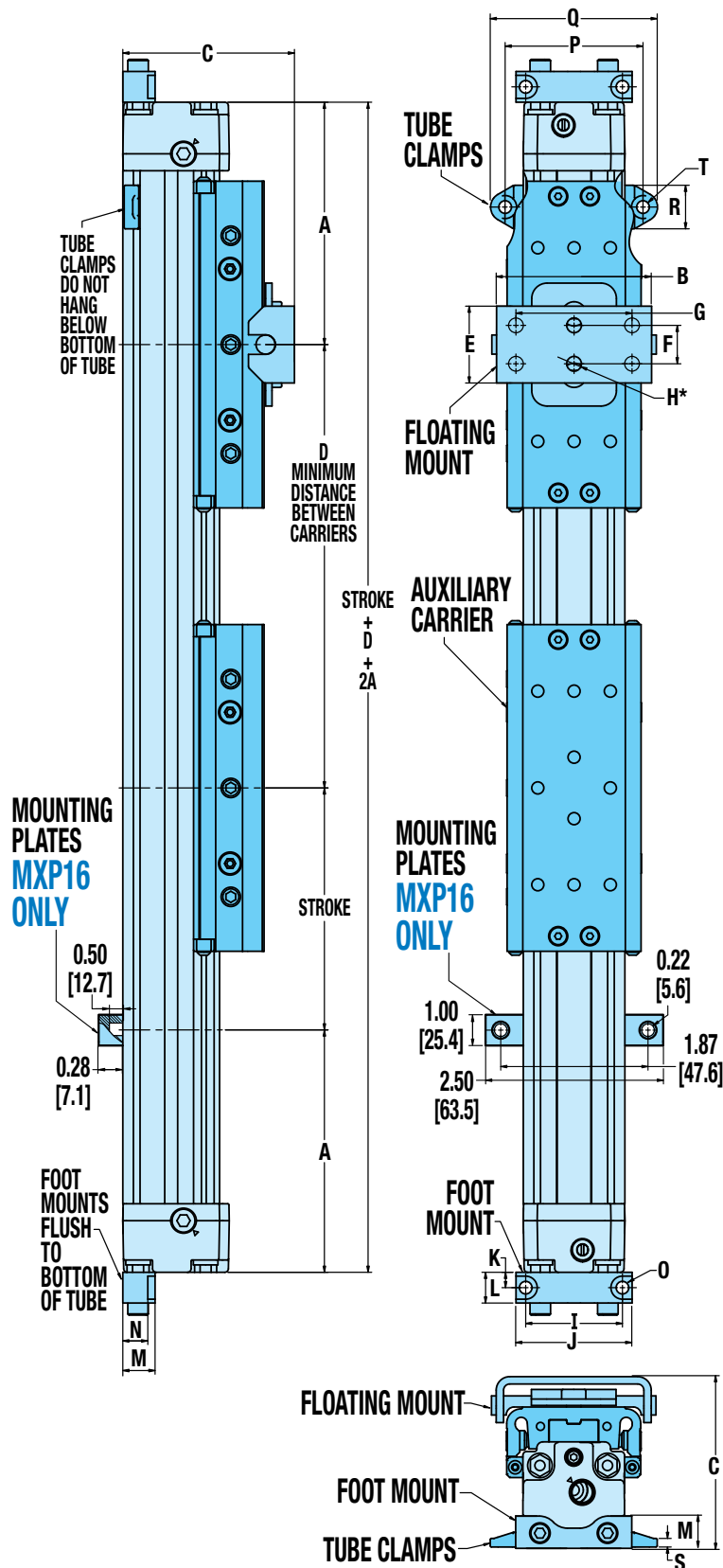

	MXP16	MXP25	MXP32	MXP40	MXP50	MXP63
A	3.13	3.94	4.90	5.82	6.29	8.45
mm	79.6	100.2	124.5	147.7	159.8	214.5
AUXILIARY CARRIER						
D	5.00	6.00	7.00	8.50	8.60	13.00
mm	127.0	152.4	177.8	215.9	218.4	330.0
FLOATING MOUNT						
B	1.86	2.52	3.37	4.32	5.04	6.10
mm	47.3	64.1	85.6	109.7	128.0	155.0
C	2.31	2.80	3.67	4.26	5.24	6.17
mm	58.7	71.0	93.3	108.2	133.1	156.8
E	0.98	1.25	2.76	3.94	3.94	5.00
mm	25.0	31.8	70.1	100.0	100.1	127.0
F	0.47	0.63	1.97	2.95	3.15	3.94
mm	12.0	15.9	50.0	74.9	80.0	100.1
G	-	-	-	2.17	-	2.76
mm	-	-	-	55.1	-	70.1
H*	0.18(2)	0.24(2)	0.28(2)	0.28(4)	0.36(2)	0.34(4)
mm	4.5(2)	6.1(2)	7.1(2)	7.1(4)	9.1(2)	8.7(4)
FOOT MOUNT						
I	1.26	1.57	2.01	2.52	3.11	3.94
mm	32.0	40.0	51.0	64.0	78.9	100.0
J	1.57	1.89	2.36	2.91	3.67	4.72
mm	40.0	48.0	60.0	74.0	93.2	120.0
K	0.16	0.25	0.37	0.47	0.50	0.59
mm	4.0	6.4	9.5	12.0	12.7	15.0
L	0.31	0.50	0.75	0.94	1.00	1.18
mm	8.0	12.7	19.0	24.0	25.4	30.0
M	0.35	0.52	0.91	0.73	1.00	1.06
mm	8.9	13.3	23.0	18.5	25.4	27.0
N	-	0.41	0.71	0.45	0.69	0.65
mm	-	10.3	18.0	11.4	17.4	16.5
O	0.18	0.20	0.22	0.28	0.35	0.42
mm	4.6	5.2	5.5	7.1	9.0	10.7
TUBE CLAMPS						
P	-	2.24	2.92	3.26	3.84	5.19
mm	-	57.0	74.1	82.7	97.5	131.7
Q	-	2.72	3.44	3.81	4.39	5.93
mm	-	69.0	87.4	96.7	111.5	150.7
R	-	0.71	0.63	0.55	0.55	0.75
mm	-	18.0	16.0	14.0	14.0	19.0
S	-	0.14	0.17	0.15	0.15	0.24
mm	-	3.6	4.3	3.8	3.8	6.1
T	-	0.20	0.28	0.28	0.28	0.42
mm	-	5.2	7.1	7.1	7.1	10.7

*MXP16, 25, 32 & 50 use 2 center holes, MXP40 & 63 use 4 corner holes

NOTE: Auxiliary carrier is S-Solid Bearing carrier, see page MXP_26 for carrier size and mounting dimensions

S-SOLID BEARING OPTION DIMENSIONS

ADJUSTABLE AND FIXED SHOCK ABSORBERS

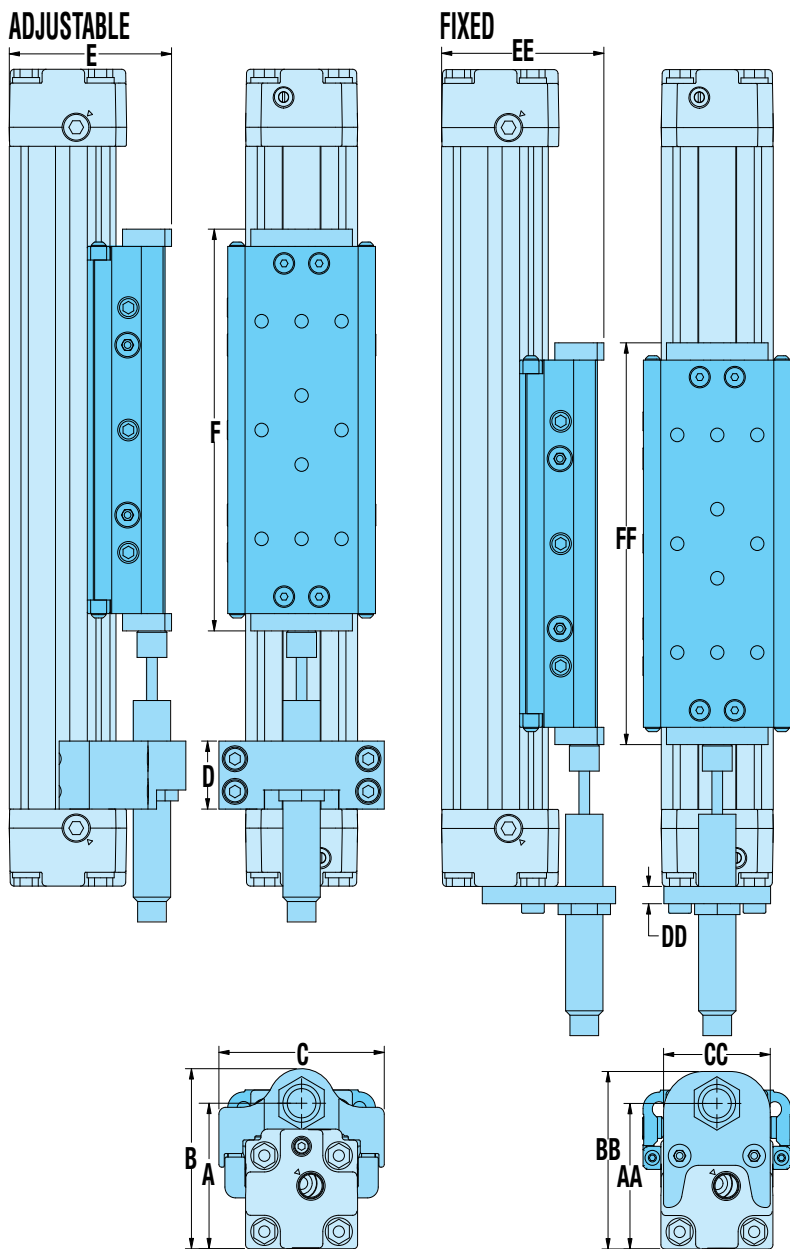

ADJUSTABLE SHOCK ABSORBER

	MXP16	MXP25	MXP32	MXP40	MXP50	MXP63
A	1.65	2.11	2.91	3.32	4.24	5.21
<i>mm</i>	42.0	53.5	73.8	84.4	107.6	132.4
B	1.97	2.61	3.35	3.87	4.87	5.91
<i>mm</i>	50.0	66.2	85.0	98.4	123.8	150.0
C	1.74	2.44	2.95	3.43	4.09	5.20
<i>mm</i>	44.3	62.0	74.9	87.0	103.9	132.0
D	0.71	0.98	1.25	0.98	1.22	1.26
<i>mm</i>	18.0	25.0	31.8	25.0	31.0	32.0
E	1.80	2.39 ¹	3.20 ²	3.57 ³	4.53 ⁴	5.50 ⁵
<i>mm</i>	45.8	60.8 ¹	81.2 ²	90.7 ³	115.1 ⁴	139.7 ⁵
F	4.12	5.81 ¹	6.76 ²	8.61 ³	8.35 ⁴	12.56 ⁵
<i>mm</i>	104.6	147.7 ¹	171.8 ²	218.8 ³	212.2 ⁴	318.9 ⁵

Stroke Adder: Adjustable Shock Absorber

	MXP16	MXP25	MXP32	MXP40	MXP50	MXP63
in.	0.62	1.50	1.96	1.70	1.66	1.65
<i>mm</i>	15.7	38.1	49.7	43.3	42.1	41.8

NOTE: For each adjustable shock absorber ordered, add Stroke Adder value to required stroke to determine configured actuator stroke.

$$\text{Required Stroke} + \left(\frac{\text{Adj. Stroke}}{\text{Quantity}} \times \text{Shock x Adder value} \right) = \text{Configured Actuator Stroke}$$

Example: MXP25S, 500mm stroke required, 2 adjustable shocks

$$500 + (2 \times 38.1) = 500 + 76.2 = 576.2\text{mm}$$

FIXED SHOCK ABSORBER

	MXP16	MXP25	MXP32	MXP40	MXP50	MXP63
AA	1.65	2.11	2.91	3.32	4.24	5.21
<i>mm</i>	42.0	53.5	73.8	84.4	107.6	132.4
BB	1.95	2.57	3.42	3.87	5.10	5.92
<i>mm</i>	49.5	65.3	86.8	98.4	129.6	150.3
CC	1.17	1.57	2.00	2.44	2.83	3.66
<i>mm</i>	29.8	40.0	50.8	62.0	72.0	93.0
DD	0.13	0.25	0.25	0.25	0.50	0.50
<i>mm</i>	3.3	6.4	6.4	6.4	12.7	12.7
EE	1.80	2.39 ¹	3.20 ²	3.57 ³	4.53 ⁴	5.50 ⁵
<i>mm</i>	45.8	60.8 ¹	81.2 ²	90.7 ³	115.1 ⁴	139.7 ⁵
FF	4.12	5.81 ¹	6.76 ²	8.61 ³	8.35 ⁴	12.56 ⁵
<i>mm</i>	104.6	147.7 ¹	171.8 ²	218.8 ³	212.2 ⁴	318.9 ⁵

¹Carrier is standard MXP25S, 2.30" (58.4mm) high X 5.31" (135.0mm) long, Impact plates on each end of carrier add .09" (2.4mm) to total height and .50" (12.7mm) to total length

²Carrier is standard MXP32S, 3.06" (77.8mm) high X 6.02" (153.0mm) long, Impact bolts on each end of carrier add .13" (3.4mm) to total height and .74" (18.8mm) to total length

³Carrier is standard MXP40S, 3.51" (89.2mm) high X 7.87" (200.0mm) long, Impact bolts on each end of carrier add .06" (1.5mm) to total height and .74" (18.8mm) to total length

⁴Carrier is standard MXP50S, 4.44" (112.8mm) high X 7.91" (200.8mm) long, Impact bolts on each end of carrier add .09" (2.3mm) to total height and .45" (11.4mm) to total length

⁵Carrier is standard MXP63S, 5.48" (139.1mm) high X 12.11" (307.5mm) long, Impact bolts on each end of carrier add .45" (11.4mm) to total length

P-PROFILED RAIL ACTUATOR DIMENSIONS

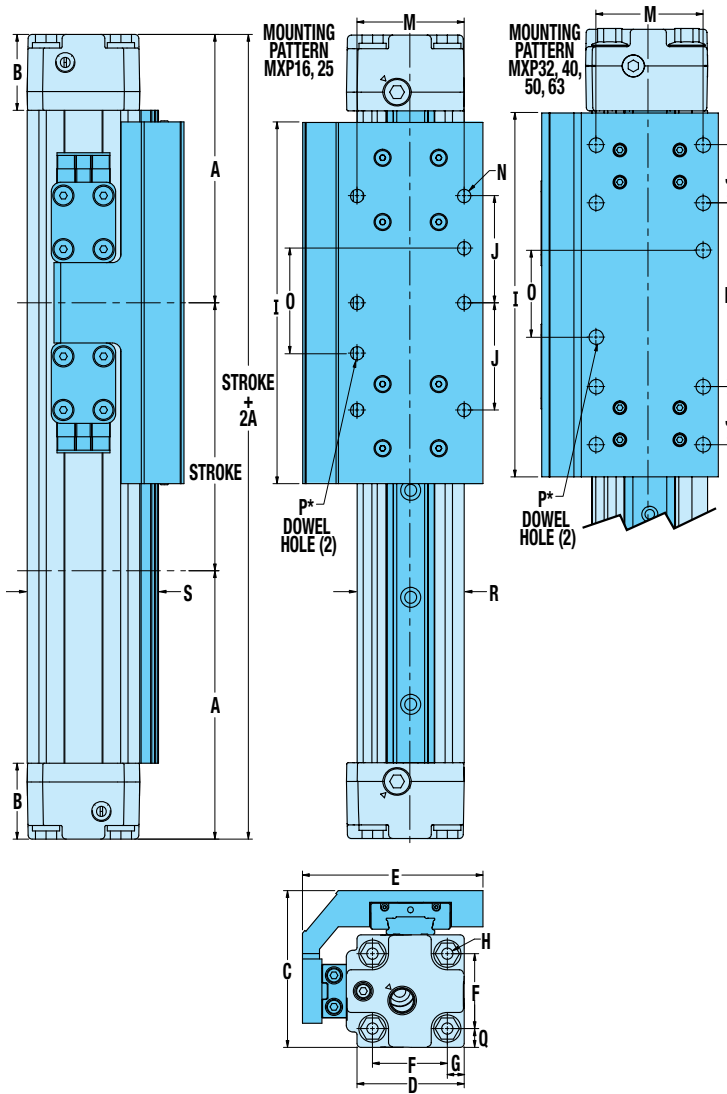

	MXP16	MXP25	MXP32	MXP40	MXP50	MXP63
A	3.13	3.94	4.89	5.79	6.26	8.42
<i>mm</i>	79.6	100.2	124.1	147.1	159.1	213.8
B	0.55	1.11	1.50	1.50	1.97	1.97
<i>mm</i>	14.0	28.3	38.1	38.0	50.0	50.0
C	1.81	2.30	3.05	3.53	4.71	5.51
<i>mm</i>	46.0	58.5	77.4	89.7	119.7	140.0
D	1.19	1.57	2.13	2.52	3.01	2.87
<i>mm</i>	30.3	40.0	54.0	64.0	78.7	73.0
E	1.78	2.65	3.25	3.85	4.62	5.65
<i>mm</i>	45.3	67.4	82.5	97.8	117.4	143.6
F	0.85	1.10	1.42	1.81	2.25	2.87
<i>mm</i>	21.5	27.9	36.1	46.0	57.2	73.0
G	0.17	0.28	0.38	0.35	0.43	0.53
<i>mm</i>	4.3	7.0	9.7	9.0	10.8	13.5
H	#8-32 (8)	#10-24 (8)	1/4-20 (8)	1/4-20 (8)	5/16-18 (8)	5/16-18 (8)
<i>mm</i>	M4x0.7 (8)	M5x0.8 (8)	M6x1.0 (8)	M6x1.0 (8)	M8x1.25 (8)	M8x1.25 (8)
I	4.33	5.31	6.69	7.87	8.50	12.00
<i>mm</i>	110.0	135.0	170.0	200.0	216.0	304.8
J	1.57	1.57	1.07	1.00	1.00	1.57
<i>mm</i>	40.0	40.0	27.1	25.4	25.4	40.0
K	-	-	3.37	4.50	2.75	5.12
<i>mm</i>	-	-	85.7	114.3	69.9	130.0
M	1.102	1.575	1.969	2.835	3.125	3.870
<i>mm</i>	28.00	40.00	50.00	72.00	79.38	98.30
N	#8-32 (6)	1/4-20 (6)	5/16-18 (8)	5/16-18 (8)	5/16-18 (10)	3/8-16 (8)
<i>mm</i>	M4x0.7 (6)	M6x1.0 (6)	M8x1.25 (8)	M8x1.25 (8)	M8x1.25 (10)	M10x1.5 (8)
O	1.575	1.575	1.772	2.500	1.500	2.559
<i>mm</i>	40.00	40.00	45.00	63.50	38.10	65.00
P*	0.1583/ .1573 ↓.250(2)	0.2520/ .2512 ↓.250(2)	0.3145/ .3135 ↓.375(2)	0.3145/ .3135 ↓.500(2)	0.3145/ .3135 ↓.500(2)	0.3770/ .3760 ↓.500(2)
<i>mm</i>	04.046 /4.021 ↓6.35(2)	06.045 /6.020 ↓6.35(2)	08.045 /8.020 ↓9.53(2)	08.045 /8.020 ↓12.70(2)	08.045 /8.020 ↓12.70(2)	010.045 /10.020 ↓12.70(2)
Q	0.17	0.28	0.38	0.35	0.43	0.53
<i>mm</i>	4.3	7.0	9.7	9.0	10.8	13.5
R	1.181	1.58	2.13	2.52	3.10	3.94
<i>mm</i>	30.00	40.00	54.00	64.00	78.74	100.00
S	1.40	1.91	2.48	2.89	3.69	4.53
<i>mm</i>	35.50	48.60	62.87	73.50	93.74	115.00

*DOWEL HOLES

\varnothing	0.003 in (M)
\varnothing	0.08 mm (M)

DUAL END PORTING

16mm
BORE

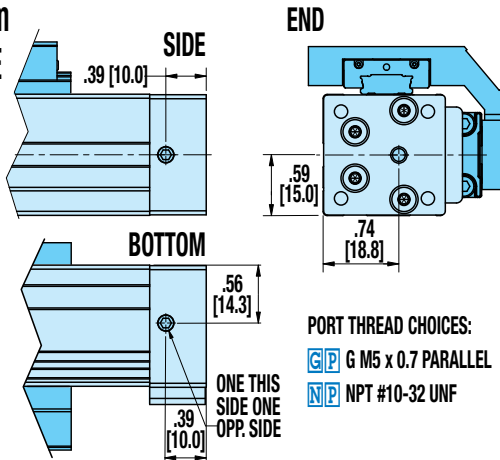

SINGLE-END PORTING

Not Available for 16mm BORE

25mm
BORE

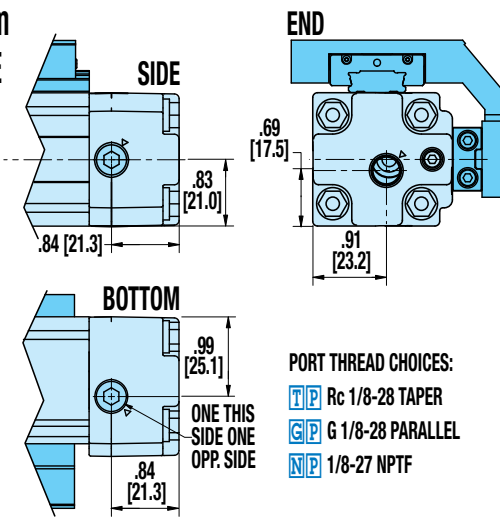

(OE = Opposite End Port)

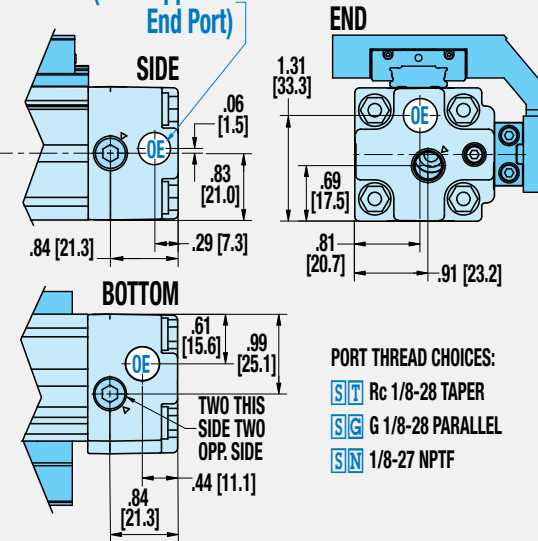

32mm
BORE

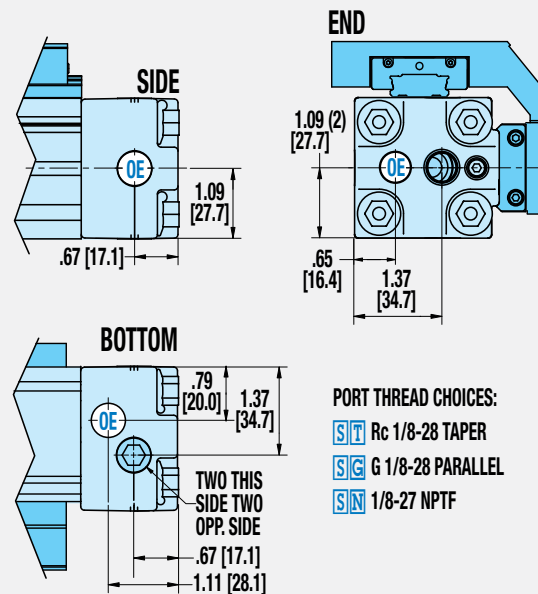
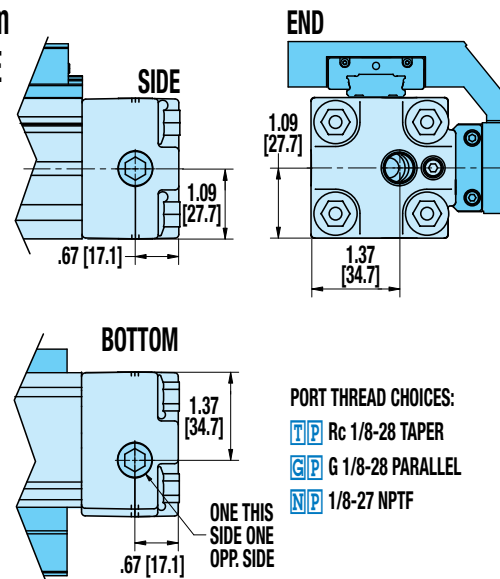

P-PROFILED RAIL PORTING DIMENSIONS MXP40P, MXP50P, MXP63P

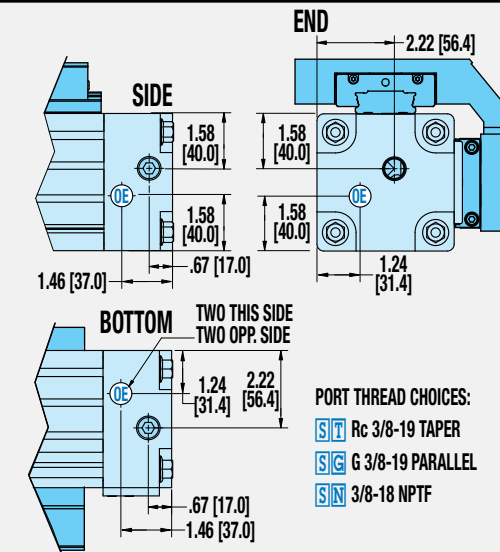
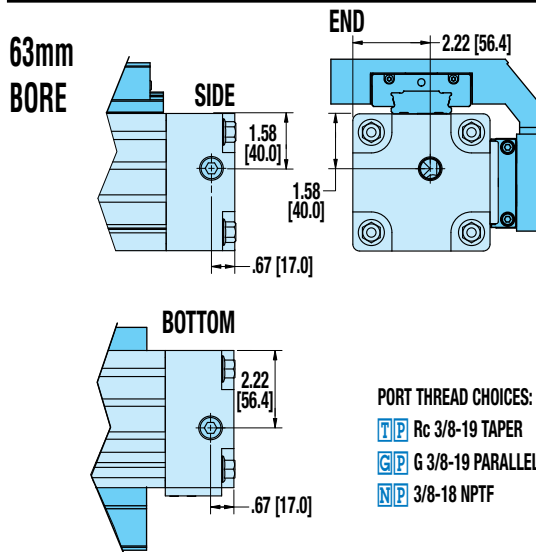
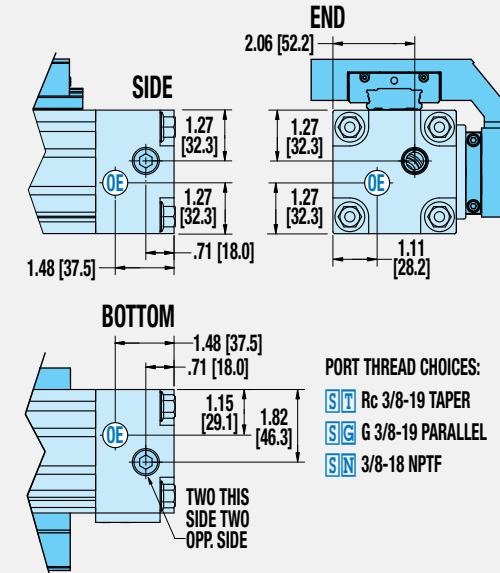
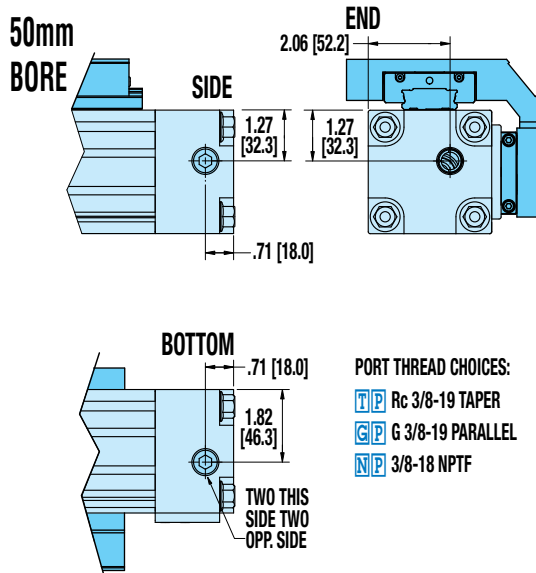
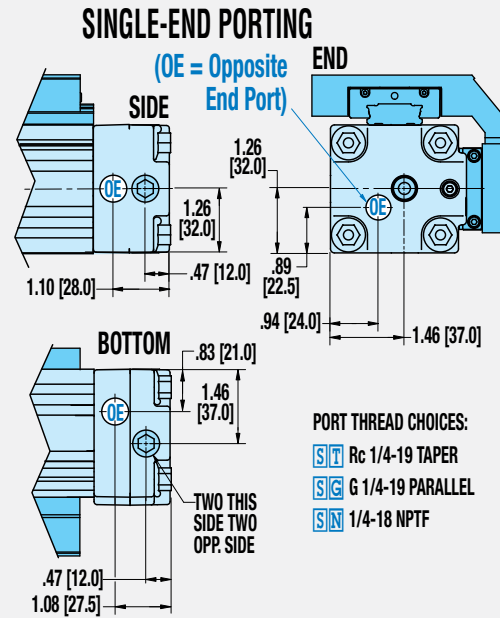
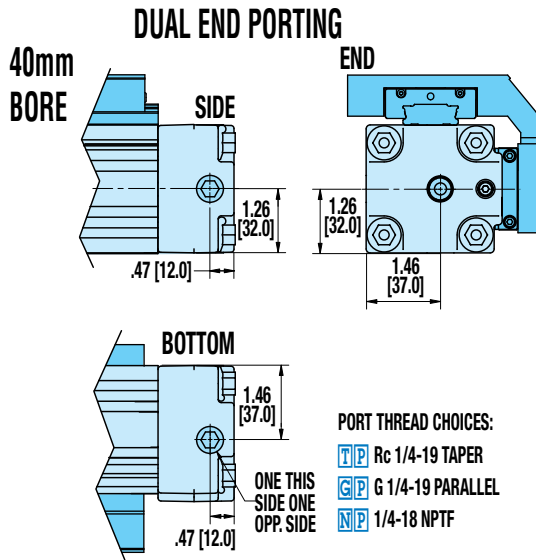

P-PROFILED RAIL OPTION DIMENSIONS

AUXILIARY CARRIER, FOOT MOUNT, TUBE CLAMPS

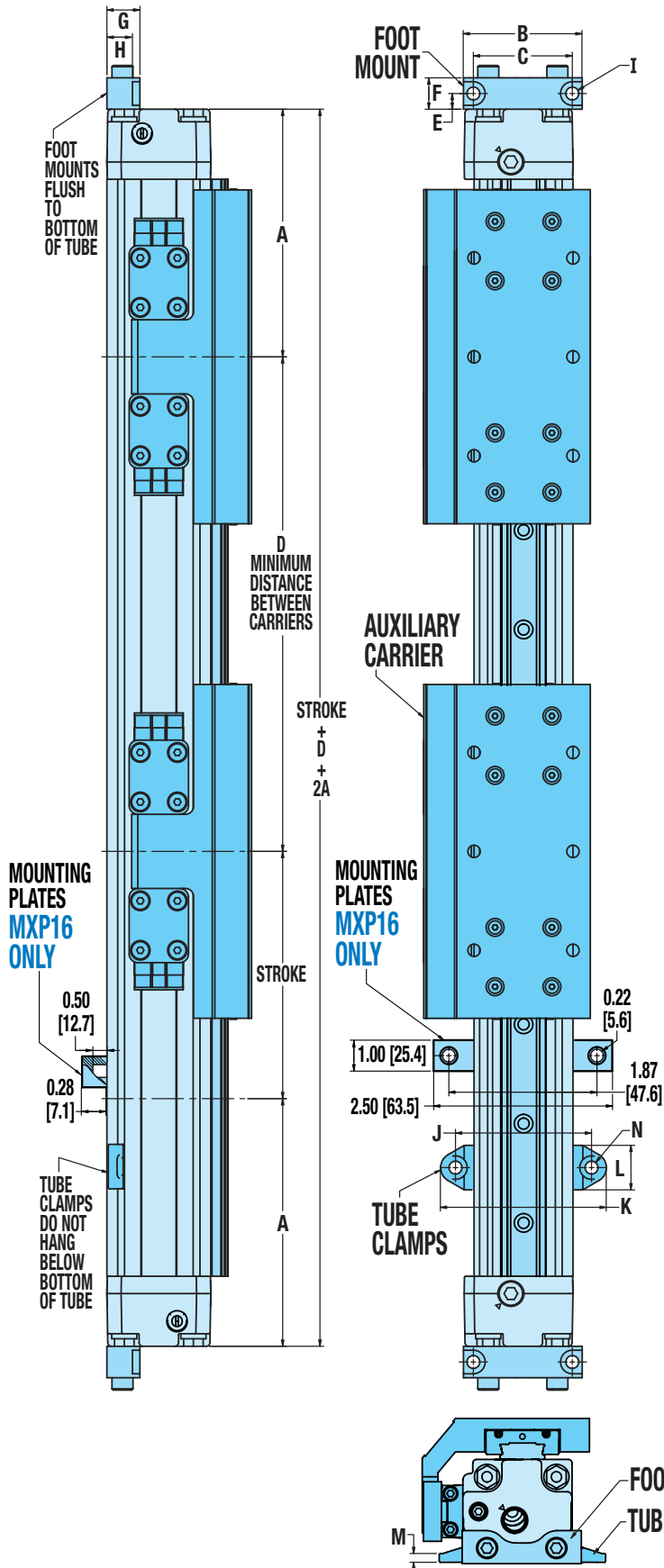

	MXP16	MXP25	MXP32	MXP40	MXP50	MXP63
A	3.13	3.94	4.90	5.82	6.29	8.45
mm	79.6	100.2	124.5	147.7	159.8	214.5
AUXILIARY CARRIER						
D	5.00	6.00	7.00	8.50	8.60	13.00
mm	127.0	152.4	177.8	215.9	218.4	330.0
FOOT MOUNT						
B	1.57	1.89	2.36	2.91	3.67	4.72
mm	40.0	48.0	60.0	74.0	93.2	120.0
C	1.26	1.57	2.01	2.52	3.11	3.94
mm	32.0	40.0	51.0	64.0	78.9	100.0
E	0.16	0.25	0.37	0.47	0.50	0.59
mm	4.0	6.4	9.5	12.0	12.7	15.0
F	0.31	0.50	0.75	0.94	1.00	1.18
mm	8.0	12.7	19.0	24.0	25.4	30.0
G	0.35	0.52	0.91	0.73	1.00	1.06
mm	8.9	13.3	23.0	18.5	25.4	27.0
H	-	0.41	0.71	0.45	0.69	0.65
mm	-	10.3	18.0	11.4	17.4	16.5
I	0.18	0.20	0.22	0.28	0.35	0.42
mm	4.6	5.2	5.5	7.1	9.0	10.7
TUBE CLAMPS						
J	-	2.17	2.86	3.26	3.84	5.19
mm	-	55.0	72.7	82.7	97.5	131.7
K	-	2.64	3.39	3.81	4.39	5.93
mm	-	67.0	86.0	96.7	111.5	150.7
L	-	0.71	0.63	0.55	0.55	0.75
mm	-	18.0	16.0	14.0	14.0	19.0
M	-	0.14	0.17	0.15	0.15	0.24
mm	-	3.6	4.3	3.8	3.8	6.1
N	-	0.20	0.28	0.28	0.28	0.42
mm	-	5.2	7.1	7.1	7.1	10.7

NOTE: Auxiliary carrier is P-Profiled Rail carrier, see page MXP_31 for carrier size and mounting dimensions

P-PROFILED RAIL OPTION DIMENSIONS

ADJUSTABLE AND FIXED SHOCK ABSORBERS

ADJUSTABLE

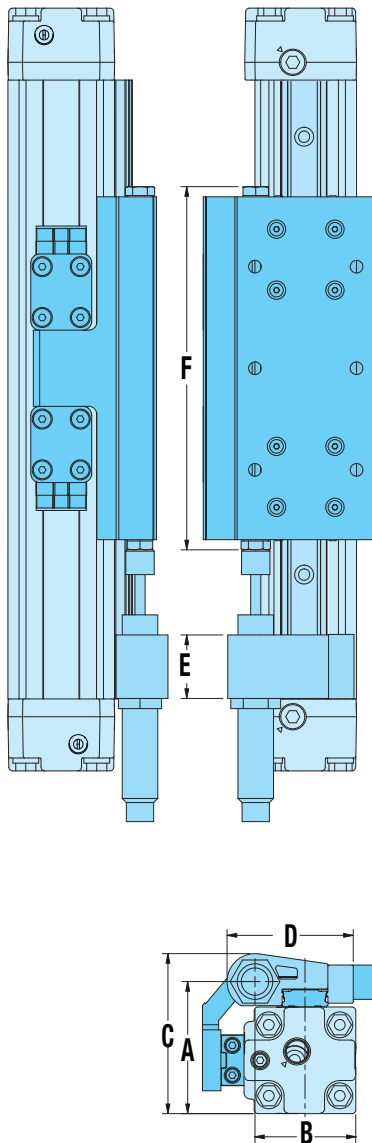

FIXED

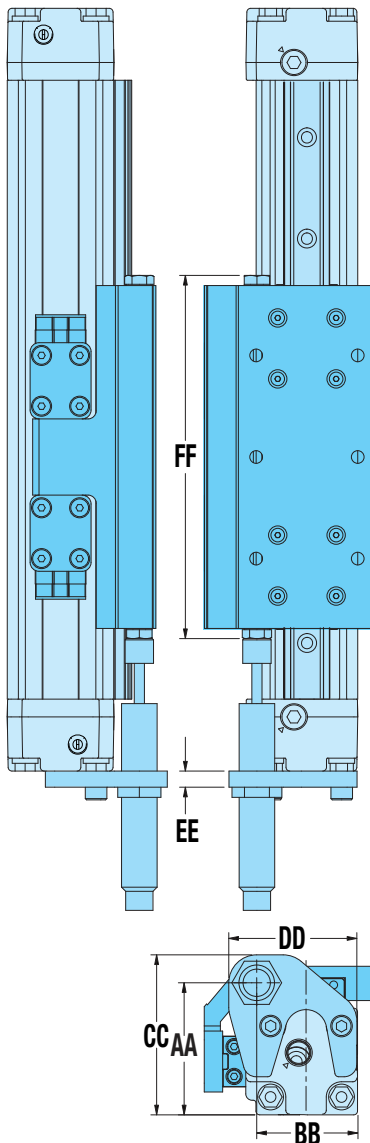

ADJUSTABLE SHOCK ABSORBER

	MXP16	MXP25	MXP32	MXP40	MXP50	MXP63
A	1.51	2.05	2.87	3.28	4.20	5.04
<i>mm</i>	<i>38.3</i>	<i>52.0</i>	<i>72.9</i>	<i>83.2</i>	<i>106.7</i>	<i>128.0</i>
B	1.38	1.56	2.25	2.63	3.55	3.97
<i>mm</i>	<i>35.0</i>	<i>39.7</i>	<i>57.2</i>	<i>66.8</i>	<i>90.2</i>	<i>100.8</i>
C	1.75	2.48	3.46	3.90	4.80	5.73
<i>mm</i>	<i>44.5</i>	<i>63.0</i>	<i>87.9</i>	<i>99.0</i>	<i>121.8</i>	<i>145.5</i>
D	1.54	1.96	2.63	3.17	3.55	4.07
<i>mm</i>	<i>39.2</i>	<i>49.7</i>	<i>66.7</i>	<i>80.6</i>	<i>90.2</i>	<i>103.3</i>
E	0.79	0.98	1.00	0.98	1.26	1.26
<i>mm</i>	<i>20.0</i>	<i>25.0</i>	<i>25.4</i>	<i>25.0</i>	<i>32.0</i>	<i>32.0</i>
F	4.65 ¹	5.63 ²	7.43 ³	8.61 ⁴	8.95 ⁵	12.45 ⁶
<i>mm</i>	<i>118.0¹</i>	<i>143.0²</i>	<i>188.8³</i>	<i>218.8⁴</i>	<i>227.4⁵</i>	<i>316.2⁶</i>

Stroke Adder: Adjustable Shock Absorber

	0.96	2.10	2.73	2.40	3.15	2.74
<i>in</i>	<i>0.96</i>	<i>2.10</i>	<i>2.73</i>	<i>2.40</i>	<i>3.15</i>	<i>2.74</i>
<i>mm</i>	<i>24.4</i>	<i>53.3</i>	<i>69.3</i>	<i>61.0</i>	<i>80.0</i>	<i>69.6</i>

▲ NOTE: For each adjustable shock absorber ordered, add Stroke Adder value to required stroke to determine configured actuator stroke.

$$\text{Required Stroke} + \left(\begin{array}{l} \text{Adj. Stroke} \\ \text{Shock} \times \\ \text{Quantity} \times \\ \text{Adder} \\ \text{value} \end{array} \right) = \text{Configured Actuator Stroke}$$

Example: MXP25P, 500mm stroke required, 2 adjustable shocks
 $500 + (2 \times 53.3) = 500 + 106.6 = 606.6\text{mm}$

FIXED SHOCK ABSORBER

	MXP16	MXP25	MXP32	MXP40	MXP50	MXP63
AA	1.51	2.05	2.89	3.32	4.38	5.22
<i>mm</i>	<i>38.3</i>	<i>52.0</i>	<i>73.4</i>	<i>84.4</i>	<i>111.2</i>	<i>132.5</i>
BB	1.38	1.56	—	—	—	—
<i>mm</i>	<i>35.0</i>	<i>39.7</i>	—	—	—	—
CC	1.80	2.48	3.41	3.87	5.09	5.93
<i>mm</i>	<i>45.8</i>	<i>63.0</i>	<i>86.5</i>	<i>98.4</i>	<i>129.2</i>	<i>150.5</i>
DD	1.66	1.98	2.00	2.44	2.83	3.66
<i>mm</i>	<i>42.2</i>	<i>50.4</i>	<i>50.8</i>	<i>62.0</i>	<i>72.0</i>	<i>93.0</i>
EE	0.13	0.25	0.25	0.25	0.50	0.50
<i>mm</i>	<i>3.3</i>	<i>6.4</i>	<i>6.4</i>	<i>6.4</i>	<i>12.7</i>	<i>12.7</i>
FF	4.65 ¹	5.63 ²	7.43 ³	8.61 ⁴	8.95 ⁵	12.45 ⁶
<i>mm</i>	<i>118.0¹</i>	<i>143.0²</i>	<i>188.8³</i>	<i>218.8⁴</i>	<i>227.4⁵</i>	<i>316.2⁶</i>

¹Carrier is standard MXP16P, 4.33" (110.0mm) long, Impact bolts on each end of carrier add .31" (8.0mm) to total length

²Carrier is standard MXP25P, 5.31" (135.0mm) long, Impact bolts on each end of carrier add .31" (8.0mm) to total length

³Carrier is standard MXP32P, 6.69" (170.0mm) long, Impact bolts on each end of carrier add .74" (18.8mm) to total length

⁴Carrier is standard MXP40P, 7.87" (200.0mm) long, Impact bolts on each end of carrier add .74" (18.8mm) to total length

⁵Carrier is standard MXP50P, 8.50" (216.0mm) long, Impact bolts on each end of carrier add .45" (11.4mm) to total length

⁶Carrier is standard MXP63P, 12.00" (304.8mm) long, Impact bolts on each end of carrier add .45" (11.4mm) to total length



SWITCHES

SPECIFICATIONS







MX products offer a large number of sensing choices. There are 12 switch choices: reed, solid state PNP (sourcing) or solid state NPN (sinking); in normally open or normally closed; with flying leads or quick-disconnects.

Commonly used for end-of-stroke positioning, these switches allow drop-in installation anywhere along the entire actuator length. The one-piece design includes the retained fastening hardware and is designed for any open side or bottom slot on the MX. The internal piston magnet is a standard feature, therefore these switches can be installed in the field at anytime.

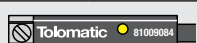
Switches are used to send digital signals to PLC (programmable logic controller), TTL, CMOS circuit or other controller device. Switches contain reverse polarity protection. Solid state QD cables are shielded; shield should be terminated at flying lead end.

All switches are CE rated and are RoHS compliant. Switches feature bright red or yellow LED signal indicators; solid state switches also have green LED power indicators.

	Order Code	Lead	Switching Logic	Power LED	Signal LED	Operating Voltage	*Power Rating (Watts)	Switching Current (mA max.)	Current Consumption	Voltage Drop	Leakage Current	Temp. Range	Shock / Vibration
REED	R Y	5m	SPST Normally Open	—	Red	5 - 240 AC/DC	*10.0	100mA	—	3.0 V max.	—	14 to 158°F [-10 to 70°C]	50 G / 9 G
	R K	Quick Disconnect											
	N Y	5m	SPST Normally Closed	—	Yellow	5 - 110 AC/DC							
	N K	Quick Disconnect											
SOLID STATE	T Y	5m	PNP (Sourcing) Normally Open	Green	Yellow	10 - 30 Vdc	*3.0	100mA	20 mA @ 24V	2.0 V max.	0.05 mA max.		
	T K	Quick Disconnect											
	K Y	5m	NPN (Sinking) Normally Open	Green	Red								
	K K	Quick Disconnect											
	P Y	5m	PNP (Sourcing) Normally Closed	Green	Yellow								
	P K	Quick Disconnect											
	H Y	5m	NPN (Sinking) Normally Closed	Green	Red								
	H K	Quick Disconnect											

Enclosure classification IEC 529 IP67 (NEMA 6)

CABLES: Robotic grade, oil resistant polyurethane jacket, PVC insulation

⚠️ *WARNING: Do not exceed power rating (Watt = Voltage x Amperage). Permanent damage to sensor will occur.

SWITCHES

WIRING DIAGRAMS

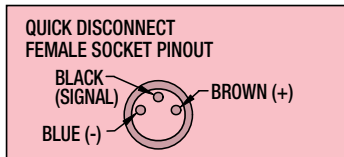
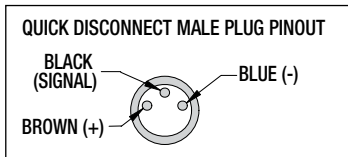
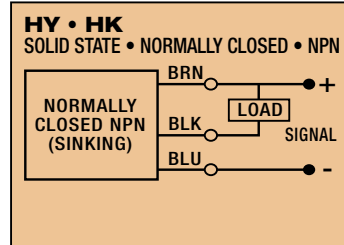
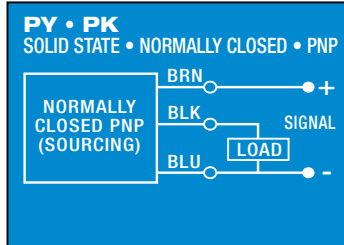
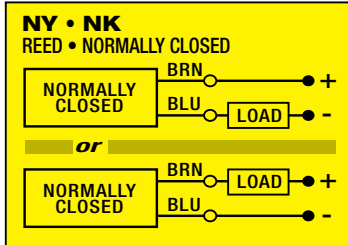
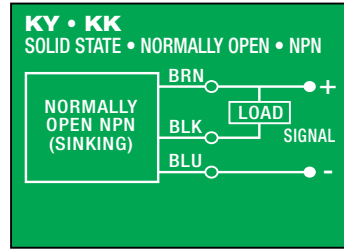
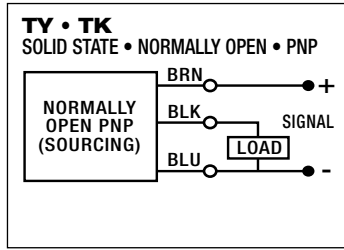
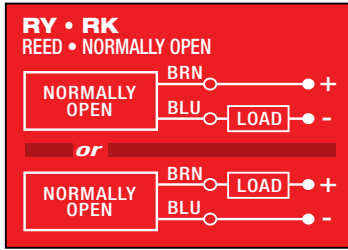

DIMENSIONS

SWITCH DIMENSIONS

Y - direct connect

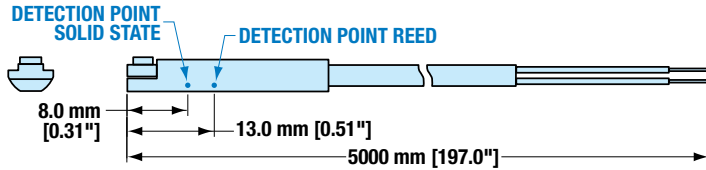

Z - QD (Quick-disconnect) switch

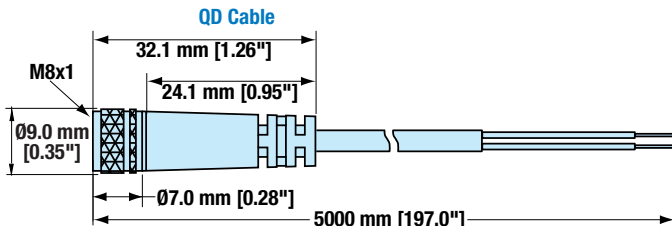
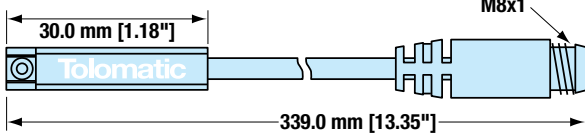

Dimensions in inches [brackets indicate dimensions in millimeters]

MOUNTING DIMENSIONS

16, 25, 32

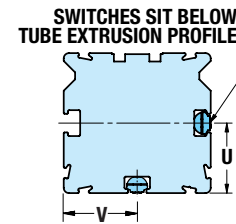

40, 50, 63

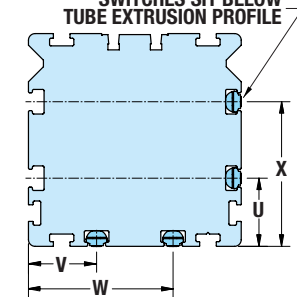

SWITCH MOUNTING

	16	25	32	40	50	63
U	0.31	0.79	1.06	0.81	1.08	1.50
mm	7.9	20.0	27.0	20.5	27.4	38.0
V	0.59	0.83	1.09	0.81	1.08	1.50
mm	15.0	21.0	27.7	20.5	27.4	38.0
W	-	-	-	1.71	2.02	2.44
mm	-	-	-	43.5	51.4	62.0
X	-	-	-	1.71	2.02	2.44
mm	-	-	-	43.5	51.4	62.0

SWITCH INSTALLATION AND REPLACEMENT

Place switch in side groove on tube at desired location with "Tolomatic" facing outward. While applying light pressure to the switch, rotate the switch halfway into the groove. Maintaining light pressure, rotate the switch in the opposite direction until it is fully inside the groove with "Tolomatic" visible. Re-position the switch to the exact location and lock the switch securely into place by tightening the screw on the switch.

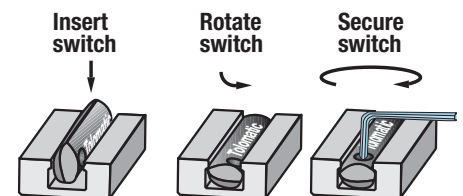

SELECTION GUIDELINES

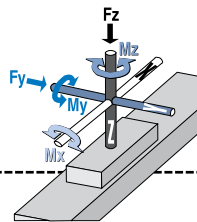

1 COMPILE APPLICATION REQUIREMENTS

APPLICATION DATA WORKSHEET

STROKE LENGTH

inch (SIZ) (U.S. Standard) millimeters (SMM) (Metric)

AVAILABLE AIR PRESSURE

PSI (U.S. Standard) bar (Metric)

REQUIRED THRUST FORCE

lbf (U.S. Standard) N (Metric)

LOAD

lb (U.S. Standard) kg (Metric)

LOAD CENTER OF GRAVITY DISTANCE TO CARRIER CENTER

d_x _____
 d_y _____
 d_z _____
 inch (U.S. Standard) millimeters (Metric)

ORIENTATION

Horizontal Side Horizontal Down

Vertical Angled α

OTHER ISSUES:

(i.e. Environment, Temperature, Contamination, etc.) _____

FORCES APPLIED TO CARRIER

lbf (U.S. Standard) N (Metric)
 F_z _____
 F_y _____

BENDING MOMENTS APPLIED TO CARRIER

in-lbs (U.S. Standard) N-m (Metric)
 M_x _____
 M_y _____
 M_z _____

FINAL VELOCITY

in/sec (U.S. Standard) mm/sec (Metric)

MOVE TIME sec. _____

NO. OF CYCLES

per minute per hour

The process of selecting a load bearing actuator for a given application can be complex. It is highly recommended that you contact Tolomatic for assistance in selecting the best actuator for your application. The following overview of the selection guidelines are for educational purposes only.

2 DETERMINE BORE SIZE

- Consult the Theoretical Force vs. Pressure graph. (See graph at right)
- Find the intersection of the available pressure and required thrust force. If the intersection falls below the plotted bore size curve, the actuator will supply adequate force for the application. If the intersection is above the curve, a larger cylinder bore size will be required.

NOTE: Additional force may be required to obtain the necessary acceleration within desired cycle time.

3 COMPARE LOAD TO MAXIMUM LOAD CAPACITIES

Calculate the following static loads: M_x , M_y , M_z , F_y , F_z

$$\text{Loads} = \text{Applied Moments} + \text{Forces}$$

If the load of your application exceeds figures indicated in the MOMENT AND LOAD CAPACITY tables (See pages MXP_10-15) consider:

- 1.) Higher capacity bearing style, i.e. **N** to **S**, **S** to **P**
- 2.) Larger Bore Cylinder
- 3.) Auxiliary Carrier
- 4.) Add External Guides

Contact information: _____



4 CALCULATE LOAD FACTOR L_F

For combined loads the Load Factor (L_F) must not exceed the value 1.

$$L_F = \frac{M_x}{M_{x_{max}}} + \frac{M_y}{M_{y_{max}}} + \frac{M_z}{M_{z_{max}}} + \frac{F_y}{F_{y_{max}}} + \frac{F_z}{F_{z_{max}}} \leq 1$$

If L_F exceeds the value 1, then consider the four choices listed in step #3.

SHOCKS

If the intersection of the final velocity and load mass falls in the shaded regions, then shock absorbers should be used.

6 CONSIDER PEAK DYNAMIC INERTIA MOMENTS

When a rigidly attached load mass is accelerated or decelerated, its inertia induces

are excessive, consider the four choices listed in step #3 or consider these deceleration methods:

- Reduce final velocity with flow controls or reduced pressure.
- Pneumatic valve deceleration circuits. By reducing the speed before the cushion or shock is reached, the load can decelerate over a longer distance, thereby reducing the deceleration moments.
- Position shock absorbers at the load's center of gravity. This will greatly reduce the moment load applied to the carrier.

P PROFILED RAIL DECELERATION CONSIDERATIONS

While the P Profiled Rail MXP is capable of carrying very large loads, consideration must be given to how to stop the load at the end of stroke. If Tolomatic cushions or shocks are used, stay within the specifications defined. If another type of shock absorber is used, be sure that the deceleration of the load is smooth and over an adequate distance.

7 DETERMINE TUBE CLAMP REQUIREMENTS

- Consult the Tube Clamp Requirement chart for the model selected (page MXP_19-20).
- Cross-reference the load force and maximum distance between supports.
- Divide stroke length by max. distance calculated above to determine number of tube clamps to order.

8 CONSIDER PORTING AND OPTIONS

- Choose Single End Porting or Dual End Porting

- Choose NPT, Metric Parallel (ISO-G/BSP) or Metric Taper (Rc/BST) Ports

OPTIONS:

- Switches – Reed, Solid State PNP or NPN, all available normally open or normally closed
- Shock Absorbers – Heavy or light duty, fixed or adjustable mount – recommended for longer life in most applications
- Foot Mounts
- Floating Mount Bracket – used when lack of parallelism occurs between the cylinder and an externally guided and supported load. Available for N internal & S solid bearing styles

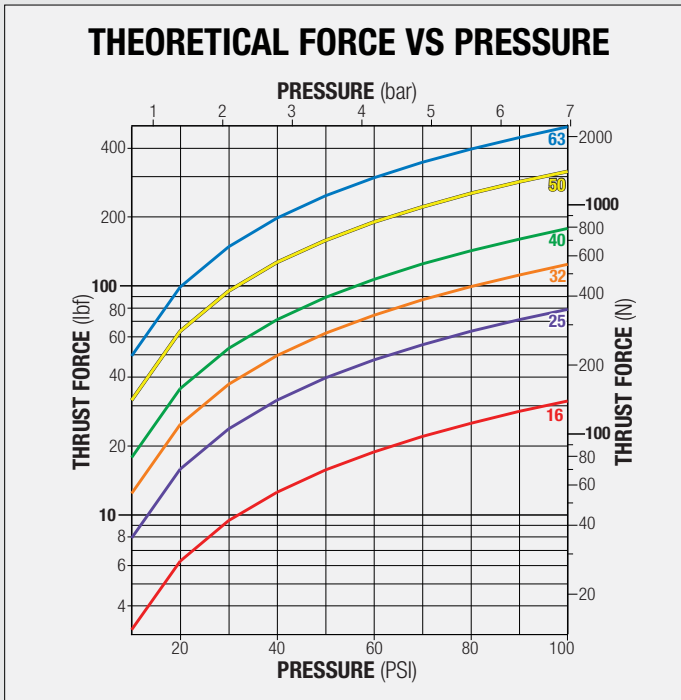

5 DETERMINE CUSHION & SHOCK CAPACITY

Consult the Cushion and Shock Absorber Performance charts for the model selected (see page MXP_18). The velocities listed on the cushion charts are final or impact velocities. If the final or impact velocity is not known, use of valve deceleration circuits or shock absorbers should be considered.

CUSHIONS

Find the intersection of the final velocity and load mass. If the intersection is below the diagonal lines, the internal cushions on the actuator may be used.

bending moments on the carrier. The magnitude of these inertia moments can be larger than the applied loads. Careful attention to how the load is decelerated at the end of stroke is required for extended actuator performance and application safety.

Evaluate the dynamic inertia moment data:

- 1.) The length of deceleration distance
- 2.) The load attached to the carrier
- 3.) The distance of the load mass center of gravity from the carrier, and
- 4.) The final velocity of the carrier.

If dynamic inertia moments

S SOLID BEARING 2:1 RULE

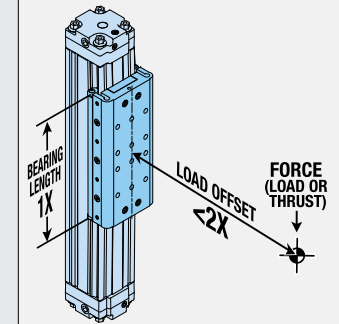

For applications using S solid bearings, binding or interrupted motion may occur if the load offset is equal to or greater than twice the bearing length (1X). *LOAD OFFSET* is defined as: the distance from the applied force (or the load center of gravity) to the centerline of the carrier.

If the load offset cannot be changed consider:

- 1.) Higher capacity bearing style, i.e. S to P
- 2.) Larger Bore Cylinder
- 3.) Auxiliary Carrier
- 4.) Add External Guides

ADJUSTMENT PROCEDURES

CUSHION NEEDLE ADJUSTMENT

Adjust the cushion needle in the cylinder heads carefully to obtain proper deceleration for your particular application. Proper cushion needle adjustment is achieved when the carrier reaches the end of travel at a velocity approaching



zero. If the carrier reaches the end of stroke at velocity, then the cushion needs to be increased by turning the cushion needle screw clockwise. If the carrier stalls or bounces (quickly oscillating directions) before it reaches the end of stroke, then the cushion needs to be decreased by turning the cushion needle screw counterclockwise. Improper cushion adjustment may cause premature failure of the actuator. Call Tolomatic with any questions.

S SOLID BEARING CARRIER ADJUSTMENT

The S solid bearing carrier will provide for maximum life when properly adjusted. The carrier design contains both tension and lock screws. The tension screws control the amount of pressure placed on the carrier bearings. The lock screws lock the tension screws in place and provide fine adjustment of the carrier bearings. The number of tension and lock screws will vary depending on the bore size of the actuator.

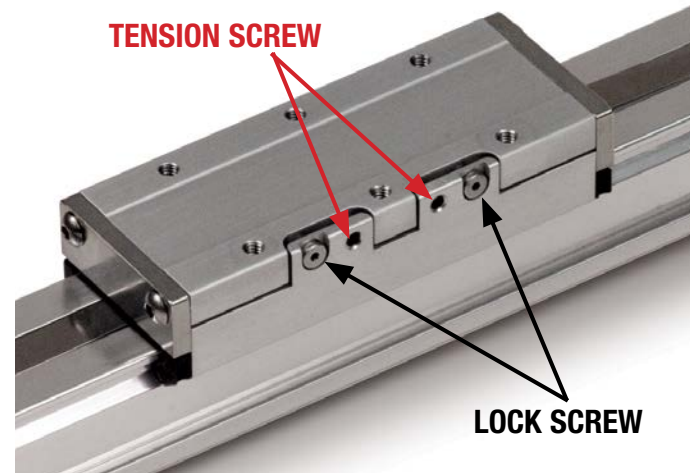
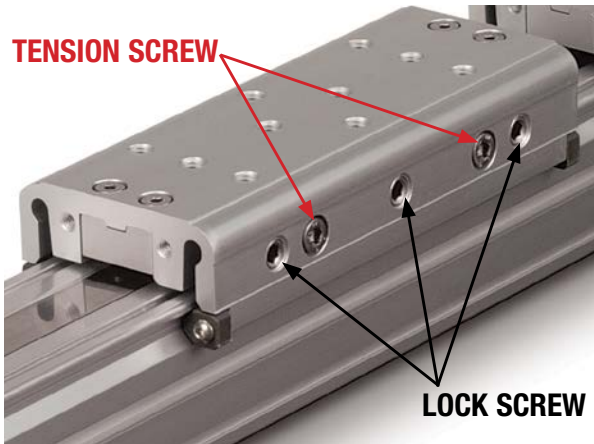

1. Fully loosen all tension and lock screws. They do not need to be removed, just fully loosened.
2. Tighten tension screws on both sides of carrier roughly 1/8 to 1/4 turn clockwise past where the screw starts to feel snug. The carrier should be very difficult or impossible to move by hand.
3. Next, adjust the lock screws on both sides of the carrier roughly 1/8 to 1/4 turn clockwise past where the screw starts to engage.
4. Ideal carrier tension is achieved when the carrier feels snug in relation to the tube. No rocking motion should be present. The carrier should be loose enough to be moved by hand over the entire length of the actuator. If after this process the carrier has become too loose, equally adjust all of the lock screws with a slight 1/32 turn counterclockwise. A carrier that is adjusted too tight will increase the breakaway pressure required for motion; in extreme cases no motion will occur when air is applied.

3. Tighten tension screws by turning them clockwise until the carrier is just tight enough so that no side-to-side rocking motion is present and it can easily be moved by hand over the entire stroke length with no hesitation. Very little torque on the screws is required to obtain this condition.

Note: The Tension Screws are the small set screw style fastener. The Lock Screws are the larger, low head, hex drive screws.

4. Tighten lock screws by turning them clockwise until tight. The carrier should feel snug in relation to the tube, with no side-to-side rocking motion present. If the carrier becomes too loose, loosen the lock screws, tighten the tension screws and then retighten the lock screws.

During the service life, this process may need to be repeated. Keeping the carrier properly adjusted will prolong the life of the S solid bearing system.

Allen wrench sizes for carrier adjustment, Solid bearing actuators

	Tension Screw		Lock Screw	
	in	mm	in	mm
16	1/16	2	1/16	2
25	5/32	4	1/8	3
32	5/32	4	3/32	2
40	5/32	4	1/8	3
50	3/16	4	3/32	2.5
63	1/4	5	3/16	5

5. Once ideal carrier tension is achieved, fully tighten end plate screws on both ends of the carrier.



NOTE: MXP16S requires a different carrier adjustment procedure, see below.

MXP16

Tools Required:

Inch Models: 1/16 inch and 2.5mm Hex Wrench (Key)

Metric Models: 2 and 2.5 mm Hex Wrench (Key)

1. Loosen endplate screws on both ends of the carrier.
2. Fully loosen all tension and lock screws. They do not need to be removed, just fully loosened.

SERVICE PARTS

REPAIR KITS

Repair kit includes: dust band, seal band, end caps, internal soft seals (piston seals, cushion seals, wipers), [Also for **S** style: bearings and bearing caps]

The part number for a repair kit begins with RK followed by model, bore size, bearing type, and stroke length (**SK** = inch/US Standard, **SM** = metric) (NOTE: If unit has an auxiliary carrier also include DW and distance between carrier centers)

Repair Kit ordering method: **RK MXP** □□□ **S** □□□□□□□□□□ **DW** □□□□□□

EXAMPLE: RK MXP 40 S SM 2007.02 DW 215.9

Repair Kit
Bore Size
Stroke Length
Auxiliary Carrier Length

Model
Bearing Type

SWITCHES

TO ORDER SERVICE PARTS SWITCHES:

Switches for MXP include retained mounting hardware and are the same for all bore sizes and bearing styles

Code	Lead	Normally	Sensor Type
R Y	5m (197 in)	Open	Reed
R K	Quick-disconnect		
N Y	5m (197 in)	Closed	Reed
N K	Quick-disconnect		
T Y	5m (197 in)	Open	Solid State PNP
T K	Quick-disconnect		
K Y	5m (197 in)	Open	Solid State NPN
K K	Quick-disconnect		
P Y	5m (197 in)	Closed	Solid State PNP
P K	Quick-disconnect		
H Y	5m (197 in)	Closed	Solid State NPN
H K	Quick-disconnect		

Switch ordering method*: **SW MXP** □□□□□□

EXAMPLE: SW MXP 25 N RK 2

Switch Kit
Bore Size
Switch Type
Quantity

Model
Bearing Type

*will include mating female QD cable if required

SERVICE PARTS MXP16, MXP25, MXP32

MOUNTING OPTIONS		16			25			32		
		N Internal	S Solid	P Profiled Rail	N Internal	S Solid	P Profiled Rail	N Internal	S Solid	P Profiled Rail
Foot Mount (1 bracket, 2 bolts)	Inch	8116-9519	8116-9519	8116-9519	8125-9519	8125-9519	8125-9519	8132-9519	8132-9519	8132-9519
	Metric	8116-9019	8116-9019	8116-9019	8125-9019	8125-9019	8125-9019	8132-9019	8132-9019	8132-9019
Tube Clamp (2 clamps)		NA	NA	NA	8125-9018	8125-9018	8125-9018	8132-9018	8132-9018	8132-9018
Floating Mount (brackets, pin, mounting fasteners)	Inch	8116-9535	8116-9536	NA	8125-9535	8125-9536	NA	8132-9535	8132-9536	NA
	Metric	8116-9035	8116-9036	NA	8125-9035	8125-9036	NA	8132-9035	8132-9036	NA
Mounting Plate (1 plate, 2 bolts)	Inch	8316-9016	8316-9016	8316-9016						
	Metric	8316-9016	8316-9016	8316-9016						

SHOCK ABSORBER KITS		16			25			32		
		N Internal	S Solid	P Profiled Rail	N Internal	S Solid	P Profiled Rail	N Internal	S Solid	P Profiled Rail
Fixed Shock Absorber Kit - Light Duty (2 shock absorbers, all required hardware)	Inch	8116-9510	8116-9511	8116-9512	8125-9510	8125-9511	8125-9512	8132-9510	8132-9511	8132-9512
	Metric	8116-9010	8116-9011	8116-9012	8125-9010	8125-9011	8125-9012	8132-9010	8132-9011	8132-9012
Fixed Shock Absorber Kit - Heavy Duty (2 shock absorbers, all required hardware)	Inch	8116-9525	8116-9526	8116-9527	8125-9525	8125-9526	8125-9527	8132-9525	8132-9526	8132-9527
	Metric	8116-9025	8116-9026	8116-9027	8125-9025	8125-9026	8125-9027	8132-9025	8132-9026	8132-9027
*Adjustable Shock Absorber Kit - Light Duty (2 shock absorbers, all required hardware)	Inch	8116-9515	8116-9016	8116-9517	8125-9515	8125-9016	8125-9517	8132-9515	8132-9016	8132-9517
	Metric	8116-9015	8116-9016	8125-9017	8125-9015	8125-9016	8125-9017	8132-9015	8132-9016	8132-9017
*Adjustable Shock Absorber Kit - Heavy Duty (2 shock absorbers, all required hardware)	Inch	8116-9530	8116-9031	8116-9032	8125-9530	8125-9031	8125-9532	8132-9530	8132-9031	8132-9532
	Metric	8116-9030	8116-9031	8116-9032	8125-9030	8125-9031	8125-9032	8132-9030	8132-9031	8132-9032

SHOCK PARTS		16			25			32		
		N Internal	S Solid	P Profiled Rail	N Internal	S Solid	P Profiled Rail	N Internal	S Solid	P Profiled Rail
Fixed Shock Absorber Mounting Hardware (1 shock mount)	Inch	8116-9520	8116-9520	8116-9522	8125-9520	8125-9520	8125-9522	8132-9520	8132-9520	8132-9522
	Metric	8116-9020	8116-9020	8116-9022	8125-9020	8125-9020	8125-9022	8132-9020	8132-9020	8132-9022
*Adj. Shock Absorber Mounting Hardware (1 shock mount)		8116-9023	8116-9023	8116-9024	8125-9023	8125-9023	8125-9024	8132-9023	8132-9023	8132-9024
Shock Stop Kit (Hardware needed for shock to strike carrier)	Inch	8116-9521	NA	8116-9034	8125-9521	8125-9013	8125-9534	8132-9521	4912-1063	8132-9534
	Metric	8116-9021	NA	8116-9034	8125-9021	8125-9013	8125-9034	8132-9021	4912-1063	8132-9034
Shock Absorber - Heavy Duty (1 shock absorber)		7906-1066	7906-1066	7906-1066	4910-1338	4910-1338	4910-1338	4912-1068	4912-1068	4912-1068
Shock Absorber - Light Duty (1 shock absorber)		7906-1065	7906-1065	7906-1065	4910-1337	4910-1337	4910-1337	4912-1067	4912-1067	4912-1067

*NOTE: **N** Internal bearing: Adjustable shock absorbers will decrease actuator stroke, see **▲** Stroke Adder note on page MXP_25 for more information.
S Solid bearing: Adjustable shock absorbers will decrease actuator stroke, see **▲** Stroke Adder note on page MXP_30 for more information.
P Profiled rail: Adjustable shock absorbers will decrease actuator stroke, see **▲** Stroke Adder note on page MXP_35 for more information.

SERVICE PARTS MXP40, MXP50, MXP63

MOUNTING OPTIONS		40			50			63		
		Internal	Solid	Profiled Rail	Internal	Solid	Profiled Rail	Internal	Solid	Profiled Rail
Foot Mount (1 bracket, 2 bolts)	Inch	8140-9519	8140-9519	8140-9519	8150-9519	8150-9519	8150-9519	8163-9519	8163-9519	8163-9519
	Metric	8140-9019	8140-9019	8140-9019	8150-9019	8150-9019	8150-9019	8163-9019	8163-9019	8163-9019
Tube Clamp (2 clamps)		8140-9018	8140-9018	8140-9018	8140-9018	8140-9018	8140-9018	8163-9018	8163-9018	8163-9018
Floating Mount (brackets, pin, mounting fasteners)	Inch	8140-9535	8140-9536	NA	8150-9535	8150-9536	NA	8163-9535	8163-9536	NA
	Metric	8140-9035	8140-9036	NA	8150-9035	8150-9036	NA	8163-9035	8163-9036	NA

SHOCK ABSORBER KITS		40			50			63		
		Internal	Solid	Profiled Rail	Internal	Solid	Profiled Rail	Internal	Solid	Profiled Rail
Fixed Shock Absorber Kit - Light Duty (2 shock absorbers, all required hardware)	Inch	8140-9510	8140-9511	8140-9512	8150-9510	8150-9511	8150-9512	8163-9510	8163-9511	8163-9512
	Metric	8140-9010	8140-9011	8140-9012	8150-9010	8150-9011	8150-9012	8163-9010	8163-9011	8163-9012
Fixed Shock Absorber Kit - Heavy Duty (2 shock absorbers, all required hardware)	Inch	8140-9525	8140-9526	8140-9527	8150-9525	8150-9526	8150-9527	8163-9525	8163-9526	8163-9527
	Metric	8140-9025	8140-9026	8140-9027	8150-9025	8150-9026	8150-9027	8163-9025	8163-9026	8163-9027
*Adjustable Shock Absorber Kit - Light Duty (2 shock absorbers, all required hardware)	Inch	8140-9515	8140-9016	8140-9517	8150-9515	8150-9016	8150-9517	8163-9515	8163-9016	8163-9517
	Metric	8140-9015	8140-9016	8140-9017	8150-9015	8150-9016	8150-9017	8163-9015	8163-9016	8163-9017
*Adjustable Shock Absorber Kit - Heavy Duty (2 shock absorbers, all required hardware)	Inch	8140-9530	8140-9031	8140-9532	8150-9530	8150-9031	8150-9532	8163-9530	8163-9031	8163-9532
	Metric	8140-9030	8140-9031	8140-9032	8150-9030	8150-9031	8150-9032	8163-9030	8163-9031	8163-9032

SHOCK PARTS		40			50			63		
		Internal	Solid	Profiled Rail	Internal	Solid	Profiled Rail	Internal	Solid	Profiled Rail
Fixed Shock Absorber Mounting Hardware (1 shock mount)	Inch	8140-9520	8140-9520	8140-9520	8150-9520	8150-9520	8150-9522	8163-9520	8163-9520	8163-9520
	Metric	8140-9020	8140-9020	8140-9020	8150-9020	8150-9020	8150-9022	8163-9020	8163-9020	8163-9020
*Adj. Shock Absorber Mounting Hardware (1 shock mount)		8140-9023	8140-9023	8140-9024	8150-9023	8150-9023	8163-9024	8163-9023	8163-9023	8163-9024
Shock Stop Kit (Hardware needed for shock to strike carrier)	Inch	8140-9521	4912-1063	8140-9534	8150-9521	4415-1003	8150-9034	8163-9521	4915-1003	8150-9034
	Metric	8140-9021	4912-1063	8140-9034	8150-9021	4415-1003	8150-9034	8163-9021	4915-1003	8150-9034
Shock Absorber - Heavy Duty (1 shock absorber)		4912-1068	4912-1068	4912-1068	4920-1069	4920-1069	4920-1069	4920-1069	4920-1069	4920-1069
Shock Absorber - Light Duty (1 shock absorber)		4912-1067	4912-1067	4912-1067	4920-1068	4920-1068	4920-1068	4920-1068	4920-1068	4920-1068

*NOTE: **I** Internal bearing: Adjustable shock absorbers will decrease actuator stroke, see **A** Stroke Adder note on page MXP_25 for more information.
S Solid bearing: Adjustable shock absorbers will decrease actuator stroke, see **A** Stroke Adder note on page MXP_30 for more information.
P Profiled rail: Adjustable shock absorbers will decrease actuator stroke, see **A** Stroke Adder note on page MXP_35 for more information.

ORDERING

MODEL SELECTION (MUST BE IN THIS ORDER)

MXP40PSN SM2007.02

OPTIONS (IN ANY ORDER)

DW215.9 FM2 TC8 TK2 AH2

MODEL

MXP MXP Pneumatic Band Cylinder

BORE

16 16 mm (5/8-inch) bore
25 25 mm (1-inch) bore
32 32 mm (1 1/4-inch) bore
40 38 mm (1 1/2-inch) bore
50 50 mm (2-inch) bore
63 64 mm (2 1/2-inch) bore

BEARING

N Internal Bearing
S Solid Bearing
P Profiled Rail

PORTING

TP Metric Taper (Rc/BST), Dual-end
GP Metric Parallel (ISO-G/BSP), Dual-end
NP NPT, Dual-end
ST Single-end, Metric Taper
SG Single-end, Metric Parallel
SN Single-end, NPT

⚠ Single End Porting **ST SG SN** is not available for MXP16
 ⚠ Metric Taper Porting **TP** is not available for MXP16

STROKE LENGTH & MOUNTING TYPE

SK _____ Stroke, enter desired stroke length in **inches**
SM _____ Stroke, enter desired stroke length in **millimeters**

NOTE: Actuator mounting threads and mounting fasteners will be either inch or metric; depending on how stroke length is indicated

SK=inch mounting
SM= metric mounting

AUXILIARY CARRIER

DW _____ Auxiliary Carrier, enter center-to-center spacing desired in **inches (SK)** or **millimeters (SM)**
 (Same unit of measure as stroke length is required)

⚠ Center-to-center spacing between carriers adds to overall length of the actuator, this distance will not be subtracted from stroke length specified in the previous step

MOUNTING

FM Foot Mount, enter quantity desired
TC Tube Clamps, enter number of pairs (Not available on MXP16)
MP Mounting Plate (includes T-Nuts) for MXP16 ONLY
FL Floating Mount

⚠ NOTE: Floating Mount is not available with "P" Profiled Rail
 ⚠ NOTE: Shock Absorbers are not available with Floating Mount

SWITCHES

RY Reed Switch (Normally Open) with 5-meter lead, & enter quantity desired
RK Reed Switch (Normally Open) with 5-meter lead/QD, & quantity
NY Reed Switch (Normally Closed) with 5-meter lead, & quantity
NK Reed Switch (Normally Closed) with 5-meter lead/QD, & quantity

TY Solid State Switch PNP (Normally Open) w/ 5-meter lead, & quantity
TK Solid State Switch PNP (Normally Open) w/ 5-meter lead/QD, & quantity
KY Solid State Switch NPN (Normally Open) w/ 5-meter lead, & quantity
KK Solid State Switch NPN (Normally Open) w/ 5-meter lead/QD, & quantity

PY Solid State Switch PNP (Normally Closed) w/ 5-meter lead, & quantity
PK Solid State Switch PNP (Normally Closed) w/ 5-meter lead/QD, & quantity
HY Solid State Switch NPN (Normally Closed) w/ 5-meter lead, & quantity
HK Solid State Switch NPN (Normally Closed) w/ 5-meter lead/QD, & quantity

SHOCK ABSORBER

SD Fixed Shock Hardware & enter quantity desired
SL Fixed Shock Light Duty & enter quantity desired
SH Fixed Shock Heavy Duty & enter quantity desired

AD Adjustable Shock Hardware & enter quantity desired
AL Adjustable Shock Light Duty & enter quantity desired
AH Adjustable Shock Heavy Duty & enter quantity desired

⚠ NOTE: Adjustable Shock Absorbers reduce usable stroke length of the actuator. Please see the following pages for required stroke adder.
N Internal Bearing.....pg. MXP_25
S Solid Bearing.....pg. MXP_30
P Profiled Railpg. MXP_35

⚠ NOTE: Floating Mount is not available with Shock Absorbers



VISIT WWW.TOLOMATIC.COM FOR COMPLETE, UP-TO-DATE INFORMATION

⚠ *Not all codes listed are compatible with all options.*

Call Tolomatic to determine available options and accessories based on your application requirements.

ELECTRIC LINEAR ACTUATORS

Rod -Screw-Drive
Rodless Belt-Drive



SERVO LINEAR ACTUATORS

Rod-Style Integrated Motor
ServoWeld



PNEUMATIC LINEAR ACTUATORS

Rodless Band Cylinders
Cable Cylinders



POWER TRANSMISSION

Right Angle Gearboxes
Industrial Caliper Disc Brakes

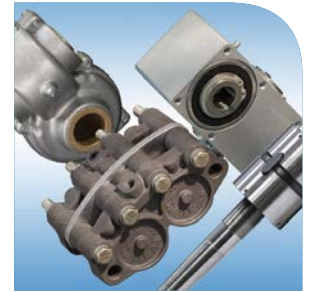

USA – Headquarters

Tolomatic, Inc.
Hamel MN 55340 USA
763-478-8000
1-800-328-2174
sales@tolomatic.com

tolomatic.com

MÉXICO

Service Center
Querétaro, Mexico
El Marqués, México
+1 (763) 478-8000
help@tolomatic.com

EUROPE

Tolomatic Europe GmbH
Rüsselsheim, Germany
+49 6142 17604-0
help@tolomatic.eu

tolomatic.com/de

CHINA

Tolomatic Automation Products
(Suzhou) Co. Ltd.
Suzhou, Jiangsu, China
+86 512 6750 8506
TolomaticChina@tolomatic.com

tolomatic.cn



Learn More
About
Tolomatic

©2026. All brand and product names are trademarks of their respective owners. Information in this document is believed accurate at time of printing. However, Tolomatic assumes no responsibility for its use or for any errors that may appear in this document. Tolomatic reserves the right to change the design or operation of the equipment described herein and any associated motion products without notice. Information in this document is subject to change without notice.

Visit www.tolomatic.com for the most up-to-date technical information.